

# ULRR

## A survey of adaptive carrier sensing mechanisms for IEEE 802.11 wireless networks

|               |   |
|---------------|---|
| Item Type     | Article   |
| Authors       | Thorpe, Christina;Murphy, Liam  |
| Citation      | Communications Surveys and Tutorials;99, pp. 1-28   |
| Publisher     | IEEE Computer Society   |
| Download date | 2026-05-14 10:01:02   |
| Item License  | <a href="https://creativecommons.org/licenses/by-nc-sa/1.0/">https://creativecommons.org/licenses/by-nc-sa/1.0/</a> |
| Link to Item  | <a href="https://hdl.handle.net/10344/3898">https://hdl.handle.net/10344/3898</a>                                   |

# A Survey of Adaptive Carrier Sensing Mechanisms for IEEE 802.11 Wireless Networks

Christina Thorpe, Liam Murphy, *Member, IEEE*

**Abstract**—This survey provides a comprehensive review of existing physical carrier sensing enhancements for IEEE 802.11 wireless networks. The original physical carrier sensing mechanism, used by wireless stations to gain access to the medium, is limited. Consequently, IEEE 802.11 networks are vulnerable to the presence of hidden and exposed nodes. Such nodes can significantly decrease system performance by increasing the collision rate and decreasing the channel spatial reuse. The value of the physical carrier sensing threshold is a key factor influencing the presence of hidden and exposed nodes in a wireless network. Several enhancements have been proposed in the literature, which attempt to mitigate the loss in performance caused by the limited carrier sensing. Firstly, the notion of an optimum carrier sensing threshold has been studied, and results indicate that it can be tuned to an optimum value. Building on the positive early results, further work was performed to develop mechanisms that dynamically adjust the threshold according to varying network conditions. This article presents an in-depth survey of the existing literature in the area, detailing the various approaches and their efficacy in addressing the problem of hidden and exposed nodes (and consequently increasing performance). It offers a comparison of the techniques, by evaluating the models, limitations, assumptions, and performance gains.

**Index Terms**—Wireless LAN, IP Networks, Wireless Communication, Wireless Networks, Ad Hoc Networks, Adaptive Algorithm, Analytical Models

## I. INTRODUCTION

**I**NCREASINGLY powerful devices are becoming available at lower and lower costs. Already, the mobile device that many people carry in their pocket is more powerful than a desktop device of 10 years ago. Increasingly powerful devices are facilitating new bandwidth-intensive services, such as video and gaming. As the number of wireless networks increases, the availability of multi-mode capable mobile devices is growing. These trends have led to heavy demands on network bandwidth; hence, spatial reuse and interference have become critical issues for the efficient delivery of content over IEEE 802.11 networks.

The IEEE 802.11 standard defines a mode of operation called the Distributed Coordination Function (DCF). DCF was designed for asynchronous communication; it relies on the Carrier Sensing Multiple Access with Collision Avoidance (CSMA/CA) algorithm for channel access. Using this protocol, multiple nodes can share the wireless channel, where (theoretically) each one has equal chance of gaining access. CSMA/CA dictates that any node wishing to transmit, must first listen to

(sense) the medium. The sensing node samples the energy on the channel to check if it is busy or idle. By comparing the sampled value to the value of a pre-defined static threshold, the node can determine the channel availability. The CSMA/CA mechanism has an inherent limitation in that it suffers from hidden and exposed nodes<sup>1</sup>. It uses a static value for the Physical Carrier Sensing Threshold (PCST), which is not optimum<sup>2</sup> across a range of different topologies. It may be too low (too sensitive) to make efficient use of the channel. Conversely, it may be too high (not sensitive enough) to effectively avoid concurrent transmissions.

Problem nodes in a Wireless Local Area Network (WLAN) essentially cause high retransmission rates and low throughput. This poor performance is shown in the results published by Borgo et al. [1] and Jayasuriya et al. [2]. Additional literature detailing the impact of problem nodes include: [3], [4], [5]. Several analytical models have been developed to examine the performance of the IEEE 802.11 MAC, and to evaluate the impact of varying the PCST. The throughput gains reported by the early models paved the way for new enhanced carrier sensing protocols. They highlighted the considerable potential performance gains that could be achieved by exploiting the sub-optimum PCST. Many of the analytical models have been validated by way of complimentary simulations.

Alawieh et al. [6] present interesting related work, published in 2009. It contains a survey of mechanisms for improving the spatial reuse in multi-hop wireless networks. Adaptation mechanisms for: Contention Window (CW); transmission power control; directional antennas; and data rate are all reviewed (in addition to PCS). The survey in this article has a narrower scope as it focuses only on adaptive PCS, however, it has more depth in that it provides a more intensive review of the available approaches. This article surveys the literature over the period 2004 - 2012 on adaptive PCS in IEEE 802.11 wireless networks.

The rest of this article is organized as follows: Section II introduces some pertinent background information, covering traditional IEEE 802.11 carrier sensing; hidden and exposed nodes; the relationship between the interference range and the Physical Carrier Sensing (PCS) range; capture effect; and the various different IEEE 802.11 architectures. Section III presents an overview of the research area and introduces a classification of the schemes published in the literature.

<sup>1</sup>Hidden and exposed nodes are collectively referenced as problem nodes in this article

<sup>2</sup>This article defines Optimum PCST as the value that maximizes aggregate system throughput by providing a good balance in the trade off between the presence of hidden and exposed nodes

| Definition   | Abbreviation |
|--|--------------|
| Access Controller  | AC           |
| Access Point   | AP           |
| Acknowledgement  | ACK          |
| Adaptive Carrier Sensing                                 | ACS          |
| Bandwidth-Dependent Overhead                             | BDO          |
| Bandwidth-Independent Overhead                           | BIO          |
| Basic Service Set  | BSS          |
| Carrier Sensing Multiple Access with Collision Avoidance | CSMA/CA      |
| Clear Channel Assessment                                 | CCA          |
| Clear to Send  | CTS          |
| Constant Bit Rate Traffic                                | CBR          |
| Contention Window  | CW           |
| Cyclic Redundancy Check                                  | CRC          |
| DCF Inter Frame Spacing                                  | DIFS         |
| Directional Antennas                                     | DA           |
| Distributed Carrier Sense Update Algorithm               | DCUA         |
| Distributed Coordination Function                        | DCF          |
| Localized Minimal Spanning Tree                          | LMST         |
| Medium Access Control Layer                              | MAC          |
| Mesh Router  | MR           |
| Mesh Router with Gateways                                | MRwGW        |
| Mobile Wireless Ad-Hoc Network                           | MANET        |
| Neighbours List  | NL           |
| Network Allocation Vector                                | NAV          |
| Network Interface Card                                   | NIC          |
| Non Line Of Sight  | NLOS         |
| Packet Error Rate  | PER          |
| Packet Loss Rate   | PLR          |
| PCS Adaptation   | PCSadapt     |
| PCS Threshold  | PCST         |
| Physical Carrier Sensing                                 | PCS          |
| Physical Layer   | PHY          |
| Point Coordination Function                              | PCF          |
| Quality of Service                                       | QoS          |
| Radio Frequency  | RF           |
| Receive Signal Strength                                  | RSS          |
| Request to Send  | RTS          |
| Short Inter Frame Space                                  | SIFS         |
| Single to Interference Noise Ratio                       | SINR         |
| Station Activity List                                    | SAL          |
| Topology Control   | TC           |
| Virtual Antenna Array                                    | VA           |
| Virtual Channel Sensing                                  | VCS          |
| Wireless Client  | WC           |
| Wireless Local Area Network                              | WLAN         |
| Wireless Mesh Network                                    | WMN          |
| Wireless Multi-Hop ad-hoc Backbone                       | WMB          |
| Wireless Multiple Access Point Networks                  | WMAPN        |

TABLE I  
LIST OF ACRONYMS

Section IV discusses the initial investigation of optimum PCS. Section V details the various approaches for optimizing the PCS mechanism for wireless ad-hoc networks. Section VI presents the proposed PCS techniques for infrastructure-based WLANs. Section VII provides a comparison of the different available approaches. Section VIII discusses possible future directions for the area. Finally, Section IX concludes the article. Table I lists the abbreviations used in this article.

## II. BACKGROUND - IEEE 802.11

IEEE 802.11 WLANs can be deployed in two ways: infrastructure-based and ad-hoc (Figure 1) [7]. The collective name for all the networking stations that communicate with one another within a WLAN is known as the Basic Service Set (BSS). In the ad-hoc architecture, all stations (WN5 - WN8)

in the BSS can communicate directly with each other without any centralized control. However, in the infrastructure-based architecture, all stations (WN1 - WN4) in the BSS associate with an Access Point (AP) and all communication occurs through it [8], [9].

The IEEE 802.11 standard provides a definition for two different operational modes: the Distributed Coordination Function (DCF) and Point Coordination Function (PCF). DCF was designed mainly for asynchronous data transport. In this mode, stations compete to access the channel; theoretically, they each have the same probability of being successful [10]. Due to the complexity and cost of implementation, PCF has never attained any significant penetration.

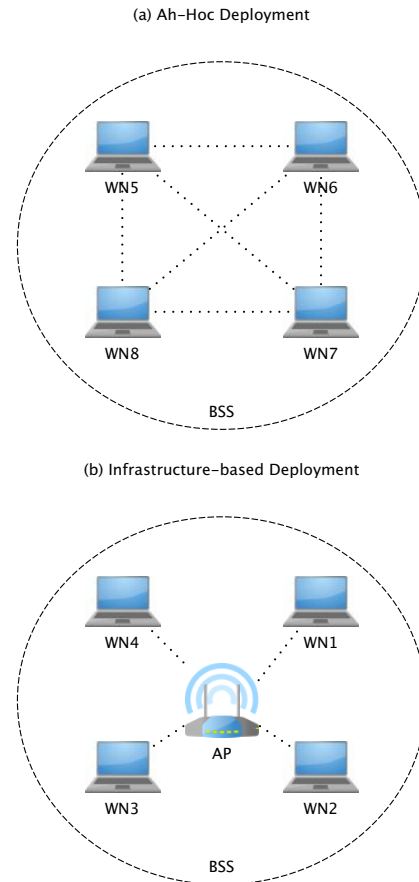

Fig. 1. IEEE 802.11 Ad-hoc and Infrastructure-Based Deployment

### A. Carrier Sensing Multiple Access with Collision Avoidance (CSMA/CA)

IEEE 802.11 defines two sensing procedures that are used to gain access the medium; namely, PCS and Virtual Channel Sensing (VCS). The PCS is performed at the Physical Layer (PHY), and it is performed via the Clear Channel Assessment (CCA) function. The VCS is performed at the Medium Access Control Layer (MAC). Both are implemented in CSMA/CA protocol [11].

1) *Physical Carrier Sensing*: Figure 2 illustrates the behaviour of PCS. When a station wishes to transmit, it must first sense the channel:

- If the channel is sensed as IDLE for a DCF Inter Frame Spacing (DIFS) period, the station starts transmitting immediately (the entire frame is sent). The transmitted frame may be destroyed at the receiver due to interference there.
- If the channel is sensed as BUSY, the station will persistently listen to the channel until it is measured IDLE for a DIFS period. The transmitter must defer the transmission for a random back-off period, and then wait for a DIFS period. If medium is still IDLE after the DIFS, the station will start transmitting.

Upon receipt of the transmitted data, the receiving station waits for a Short Inter Frame Space (SIFS) period, before sending an Acknowledgement (ACK) back to the transmitter. When the sending station experiences packet losses or senses a busy medium, it backs-off for a random time period (ranging from 0 to the CW) [12]. The CW is initialized to a value between 0-7 time slots. The station picks a random number within this range and uses it to generate its back-off time. When the back-off reaches 0, and the medium is free, the station starts transmitting. Otherwise it doubles the maximum CW size (up to some pre-defined limit) and repeats the same procedure.

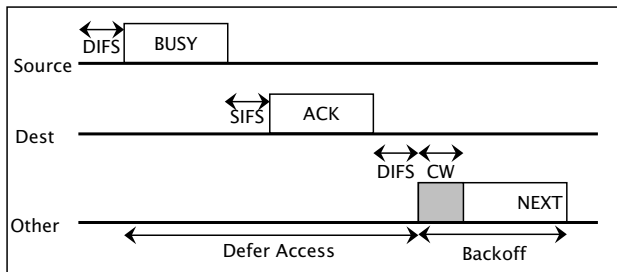

Fig. 2. CSMA/CA Physical Carrier Sensing

2) *Virtual Carrier Sensing*: The second mode of CSMA/CA operation uses VCS, illustrated in Figure 3. Four stations are depicted in the scenario (A, B, C, and D). Stations B and C are within range of A. Station D is out of range of A, but is within range of B. Station A wishes to transmit to B; it begins by sending a Request to Send (RTS) frame to B, essentially asking permission to send B a data frame. When B receives the RTS, it replies by sending a Clear to Send (CTS) frame back to A. On receipt of the CTS, A sends the data frame and starts an ACK timer. Upon successful receipt of the data frame, B responds with an ACK frame. If A receives the ACK from B before the ACK timer expires, the exchange is complete. If not, the entire protocol must run again.

Station C also receives the RTS frame from A (within range), and determines that a station is going to start transmitting data imminently. Station C sets a Network Allocation Vector (NAV) for the required amount of time (calculated from information in the RTS frame). The NAV asserts a virtual

channel busy state, and Station C does not transmit anything until the NAV expires. Station D does not receive the RTS, but it does receive the CTS, so it also sets the NAV signal for itself. All RTS and CTS packets are subject to the PCS procedure for transmission (discussed in section II-A1).

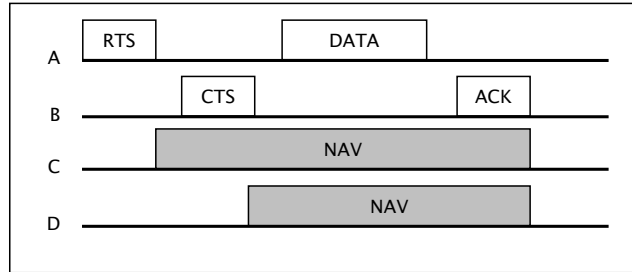

Fig. 3. CSMA/CA Virtual Carrier Sensing

VCS is optional in IEEE 802.11; moreover, it is not recommended for use with packets that have a small payload because of the significant signaling overhead that is involved in exchanging the RTS/CTS packets. Since RTS/CTS is largely out of users' control (VCS is triggered when packet size exceeds a threshold), it cannot be relied on for network optimisation. The key message in [13], [14] and [15] is that VCS is not an optimum solution, and enabling it can actually reduce the spatial reuse. Several example scenarios are detailed in [16]; results show a decrease in throughput suffered with the use of RTS/CTS (compared to disabled RTS/CTS).

**B. Problem Nodes**

The presence of problem nodes in WLANs cause considerable system performance degradation. The hidden node problem occurs when a transmitting node is visible from a receiving node, but not from other nodes wishing to transmit to the same receiver (PCST is not sensitive enough). The exposed node problem occurs when a node is incorrectly prevented from transmitting due to neighboring transmitters (PCST is too sensitive).

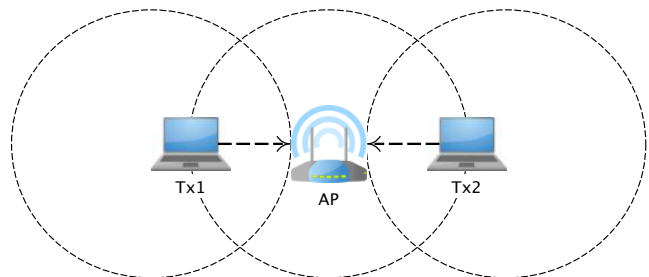

Fig. 4. Hidden Node Problem

1) *Hidden Nodes*: The hidden node problem is illustrated in Figure 4, which consists of a basic configuration including an Access Point (AP) and two wireless transmitting nodes,  $Tx_1$  and  $Tx_2$ . Both transmitters can communicate with the AP, but

the distance between them means they cannot sense the other's ongoing transmissions (hidden from each other), thus, neither of the nodes will back-off. Instead, the two transmitters must contend to transmit to the AP. If one transmitter consistently has a stronger received signal strength at the AP, it could monopolize the channel, resulting in severe connectivity problems at the other transmitter.

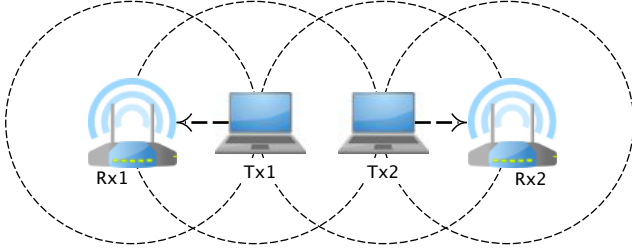

Fig. 5. Exposed Node Problem

2) *Exposed Nodes*: Figure 5 illustrates the exposed node problem. The network shown consists of two receivers  $Rx_1$ ,  $Rx_2$ , and two transmitters  $Tx_1$ ,  $Tx_2$ .  $Rx_1$  is not in range of  $Tx_2$ , and  $Rx_2$  is not in range of  $Tx_1$ , however, the two transmitters are in range of each other. If  $Tx_1$  is transmitting to  $Rx_1$ ,  $Tx_2$ 's transmission to  $Rx_2$  is deferred due to the PCS. The CCA will wrongly conclude that the ongoing transmissions sensed on the channel will result in a collision with  $Tx_2$ 's transmission. In actuality, the receiver,  $Rx_2$ , would successfully receive the transmission from  $Tx_2$  because it is not within the interference range of  $Tx_1$ .

### C. Relationship between the Carrier Sense Range and Interference Range

Using free space path loss, the mean Received Signal Strength (RSS) can be written as a function of the distance from the transmitting node to the receiving node, as in (1). Depending on the environment, the path-loss exponent  $\delta$  has a value between 2 and 4. The RSS is the signal strength at the receiving node  $n_{rx}$ . The distance between the transmitter  $n_{tx}$  and the receiver  $n_{rx}$  is denoted by  $d_{(tx,rx)}$ .  $\overline{RSS}$  is the power of the signal received at a defined distance,  $\bar{d}$  (typically 1 meter), from the transmitter.

$$RSS = \overline{RSS} \left( \frac{\bar{d}}{d_{(tx,rx)}} \right)^\delta \quad (1)$$

The total power received at any node is calculated with the interference, noise, and received signal. A receiver,  $n_{rx}$ , will receive the signal successfully only if certain conditions are met: (a) RSS of the signal is greater than the receiver sensitivity, and (b) the Signal to Interference plus Noise Ratio (SINR) exceeds a pre-defined threshold (defined for correct reception). The PCS range,  $D_{cs}$ , and the reception range,  $D_{rx}$ , can be calculated by (2), where  $T_{rx}$  and  $T_{cs}$  denote the receive

threshold and the PCST respectively.

$$D_{cs} = \bar{d} \left( \frac{\overline{RSS}}{T_{cs}} \right)^{\frac{1}{\delta}} \quad (2)$$

$$D_{rx} = \bar{d} \left( \frac{\overline{RSS}}{T_{rx}} \right)^{\frac{1}{\delta}}$$

The interference range<sup>3</sup>,  $D_{I_{tx,rx}}$ , of a receiving node,  $n_{rx}$ , is the greatest distance from which it can be affected by another transmitting node,  $n_{tx}$ .  $D_{I_{tx,rx}}$  is calculated by (3).

$$D_{I_{tx,rx}} = d_{(tx,rx)} \times \alpha^{\frac{1}{\delta}}, \quad (3)$$

where  $\alpha$  is the minimum SINR required to achieve a correct decoding of the signal at the receiving node.

Figure 6 depicts the relationship between  $D_{cs}$  and  $D_{I_{tx,rx}}$ .  $D_{I_{tx,rx}}$  is represented by the smaller circle with the solid line, and  $D_{cs}$  is depicted by the larger circle with the broken line. The crescent between the broken line and the dotted line shows the hidden region.

Node  $n_h$  is a hidden node: it is outside the PCS range of  $n_{tx}$ , but is within the interference range of  $n_{rx}$ . Node  $n_e$  is an exposed node: it is outside the interference range of  $n_{rx}$ , but inside the PCS range of  $n_{tx}$ . The probability of hidden nodes being present is lower as the PCS range,  $D_{cs}$ , gets bigger ( $T_{cs}$  becomes more sensitive), however, the probability of exposed nodes is higher. Vice versa when  $D_{cs}$  gets smaller.

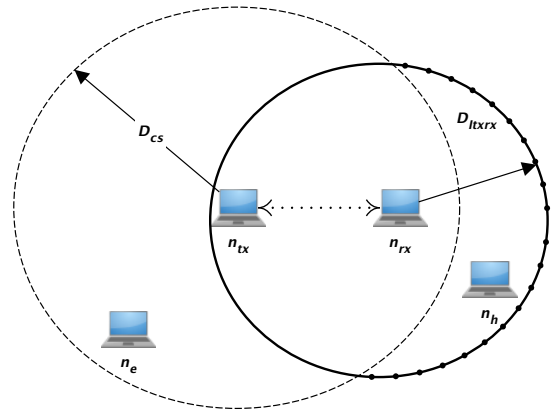

Fig. 6. Relationship between  $D_{cs}$  and  $D_{I_{tx,rx}}$

### D. Capture Effect

A packet contains a preamble, a synchronisation byte, headers, data, and a Cyclic Redundancy Check (CRC) byte (Figure 7). When two transmitters are simultaneously transmitting to the same receiver, Capture Effect (CE) can be defined as: the ability of some radios to receive a signal from one transmitter, even if the relative strength of the two signals are almost the same [18]. When capture is present, there are two possible types of interference:

<sup>3</sup>The term 'interference range' is used throughout the article; however, this could more precisely be called the 'vulnerability circle'. Transmitters outside this range will also interfere with the intended receiver, but their interference will not cause a collision [17].



Fig. 7. IEEE 802.11 Packet Format

1) *Stronger-first*: where the stronger signal arrives first. The stronger signal is received normally because the radio synchronizes with the stronger signal. The weaker interfering signal does not prevent the reception of the stronger signal, due to the capture effect (Figure 8).

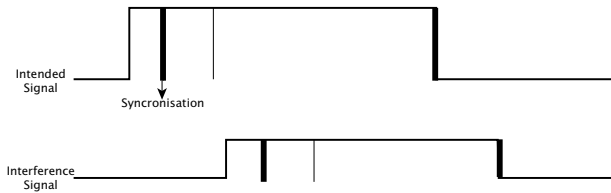

Fig. 8. Stronger-First

2) *Stronger-last*: where the stronger signal arrives last. The radio synchronizes with the weaker signal, but reception fails due to the stronger signal later capturing the channel (after  $t$ ). This corrupts the end of the first weaker signal, and results in the loss of both packets (Figure 9). Work in [18] attempts to mitigate the loss of the stronger signal. The paper presents a mechanism to continually scan for new preambles (during a reception), and to resynchronize to the new signal in the stronger-last scenario.

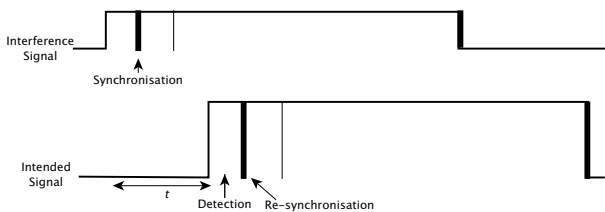

Fig. 9. Stronger-Last

### E. Wireless Ad-Hoc Networks

Wireless ad-hoc networks consist of a group of wireless devices communicating over radio links [19]. The nodes forming an ad-hoc network, do so in a dynamic and self-organized fashion that enables inter-networking in areas with no existing infrastructure. The proliferation of WLANs and the availability of powerful, affordable, mobile devices have driven the demand for extending the coverage of wireless access - users want ubiquitous connectivity. However, the coverage of WLANs is bound by the transmission power of the wireless devices, which is restricted by regulations.

Traditional IEEE 802.11 networks rely on cables to bridge between stations outside the WLAN; this is an expensive and inflexible approach. One possible solution for eliminating the reliance on fixed cabling is the use of Wireless Mesh Networks (WMNs) [20] [21]. The IEEE 802.11s amendment defines protocols for IEEE 802.11 nodes to form self-configuring multi-hop WMNs that support all methods of data transmission (e.g., unicast, multicast, broadcast).

### F. Wireless Multiple Access Point Networks (WMAPN)

Zhu et al. [22] propose a multiple AP architecture to increase spatial reuse and power efficiency, network coverage, and to reduce outages. A WMAPN consists of several APs operating on the same channel. Every user can sense multiple APs within the PCS range, and can use a selection algorithm to associate with multiple APs.

Multiple WMAPNs can be successfully deployed in an area by ensuring that they are set to operate on non-overlapping or orthogonal channels. Figure 10 illustrates a typical WMAPN. The three key devices forming such a network include: APs, users, and an Access Controller (AC). The AC is a central management entity responsible for coordinating all APs. Each AP has two different categories of interfaces: wireless Network Interface Cards (NICs) to communicate with wireless users, and a wired NIC to communicate with the AC. The AC makes AP selection decisions and maintains lists of current associations.

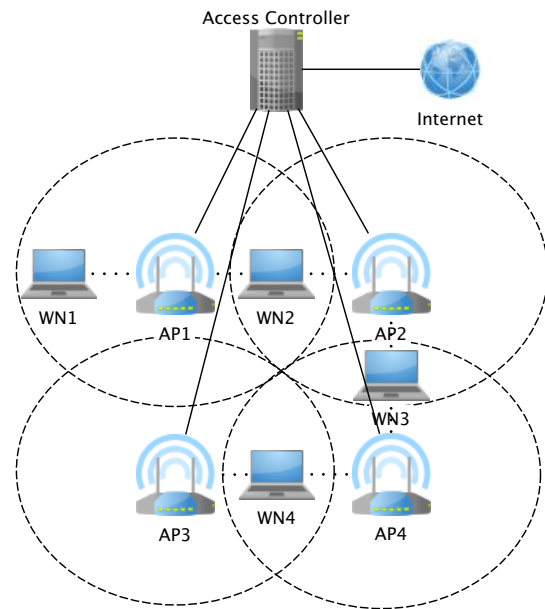

Fig. 10. MAP WLAN Architecture

## III. OVERVIEW OF RESEARCH AREA

Addressing the limitations of the CSMA/CA algorithm for IEEE 802.11 networks has been a hotspot of activity for nearly ten years, with the majority of the literature published proposing adaptive PCS schemes. This section provides an

overview of the research area, and offers a categorisation of PCS adaptation that differentiates based on the target wireless architecture.

#### A. Benefits of Adaptive PCS

Spatial reuse is a key performance issue in WLANs; managing it effectively can facilitate multiple simultaneous transmissions. Hence, it can proportionally increase aggregate network throughput. Maximising spatial reuse requires a MAC protocol that is fine grained and tunable, to enable transmitting nodes to maintain the optimum sensitivity level (that is sufficient to avoid collisions from interference). The traditional CSMA/CA protocol is sub-optimal, and suffers from problem nodes. Maximising spatial reuse can be achieved through a balance between exposed and hidden nodes. The value of the PCST is instrumental in achieving this balance, thus, it forms the basis for the majority of the approaches in the literature.

Using RF path-loss models, the PCST can be translated as the minimum distance that is effectively possible between simultaneous transmitters. This minimal distance is influenced by various network properties, therefore, the PCST should be selected in accordance with the network conditions. Furthermore, wireless networks are inherently dynamic in nature, hence, dynamic mechanisms are needed to tune the PCST in-line with the changing network conditions. However, the traditional IEEE 802.11 MAC uses a static PCST, which cannot be tuned. As a result of this coarse granularity, PCS often leads nodes to be either too conservative or too aggressive. Efficaciously tuning the PCST can afford a substantial performance improvement in the form of increased throughput and decreased collision rates. Quality of Service (QoS) can be supported by bounding certain network statistics (e.g., packet loss) in a desired range when tuning the PCST.

#### B. Adaptive PCS Breakdown

Since its inception in 2004, adaptive PCS mechanisms for IEEE 802.11 networks have received a lot of attention from the research community. The limitations of the CSMA/CA protocol, and the potential performance gains afforded by optimising the PCST, has resulted in an attractive and interesting research problem. The various contributions to the area can be categorized based on the IEEE 802.11 architecture that the work specifically targets. A breakdown of these categories is illustrated in Figure 11.

All the work falls under the root category of IEEE 802.11 adaptive PCS. There are three middle layer categories, including:

- 1) Investigation of optimum carrier sensing threshold - detailing the preliminary analysis of the notion of an optimum PCST. This topic can be further broken down into MAC overhead-aware, and MAC overhead unaware-models.
- 2) Adaptive PCS for wireless ad-hoc networks - containing all the work targeting ad-hoc networks. There are several lower level categories stemming from the ad-hoc architecture. These include: basic multi-hop ad-hoc

mechanisms, loss differentiation-aware adaptation, mobile ad-hoc network mechanisms, adaptation for topology controlled networks, and alternatives to CSMA/CA.

- 3) Adaptive PCS for wireless infrastructure networks - containing all the approaches for infrastructure WLANs. The lower layer sub categories stemming from this include adaptation for single and multiple AP systems.

The precise definition of adaptive carrier sensing depends on the different proposed solutions; For example, some vary over time only, some vary over space only, and some vary over both time and space. Some of the early literature discussed uses a static optimized PCST that is calculated offline and does not adapt. The term is defined clearly in each of the subsections.

### IV. OPTIMAL PHYSICAL CARRIER SENSING

The inception of adaptive PCS began with the initial investigation into the PCST and its impact on system performance. This preliminary work laid the foundation for further advancement in the area.

#### A. Tuning the Carrier Sense Range of the IEEE 802.11 MAC

Deng et al. [15] evaluate the IEEE 802.11 carrier sensing range. The authors argue that this range is a parameter that can be tuned, which has the potential to considerably impact the performance of multi-hop mesh nodes' MAC. This work does not present an adaptive mechanism - it is a reward function-driven investigation of the concept of an optimum PCST, with respect to maximising the network throughput and minimising the number of data packet collisions.

A cost function,  $g(t)$ , is defined to represent the time it takes for a packet transmission. Since it takes a significantly longer time to transmit a data packet than a control packet, the cost of control packets is considered to be negligible (4):

$$g(t) = \begin{cases} c, & \text{for data transmissions} \\ 0, & \text{for all control packet transmissions} \end{cases} \quad (4)$$

The total reward is defined in (5):

$$\eta = N_s - cN_d, \quad (5)$$

where  $N_s$  denotes the throughput (bits/s), and  $N_d$  denotes the total transmitted data (bit/s). This reward function tries to increase channel throughput and decrease unnecessary packet transmissions (retransmissions). The parameter,  $c$ , denotes the relationship between the cost of transmitting one bit and the benefit of successfully receiving one bit. The authors show that the sensing range can be optimally tuned for different values of  $c$  with respect to maximising the total reward,  $\eta$ .

Preliminary tests were conducted to obtain baseline results, observations included: (a) the probability of a successful data packet transmission increases as the PCS range increases i.e., the greater the sensitivity of the PCST, the lower the probability of simultaneous transmissions on interfering links. (b) The probability of a successful transmission is lower when the RTS/CTS scheme is used. Once the RTS/CTS exchange has occurred, the channel is not sensed again. Nodes that are

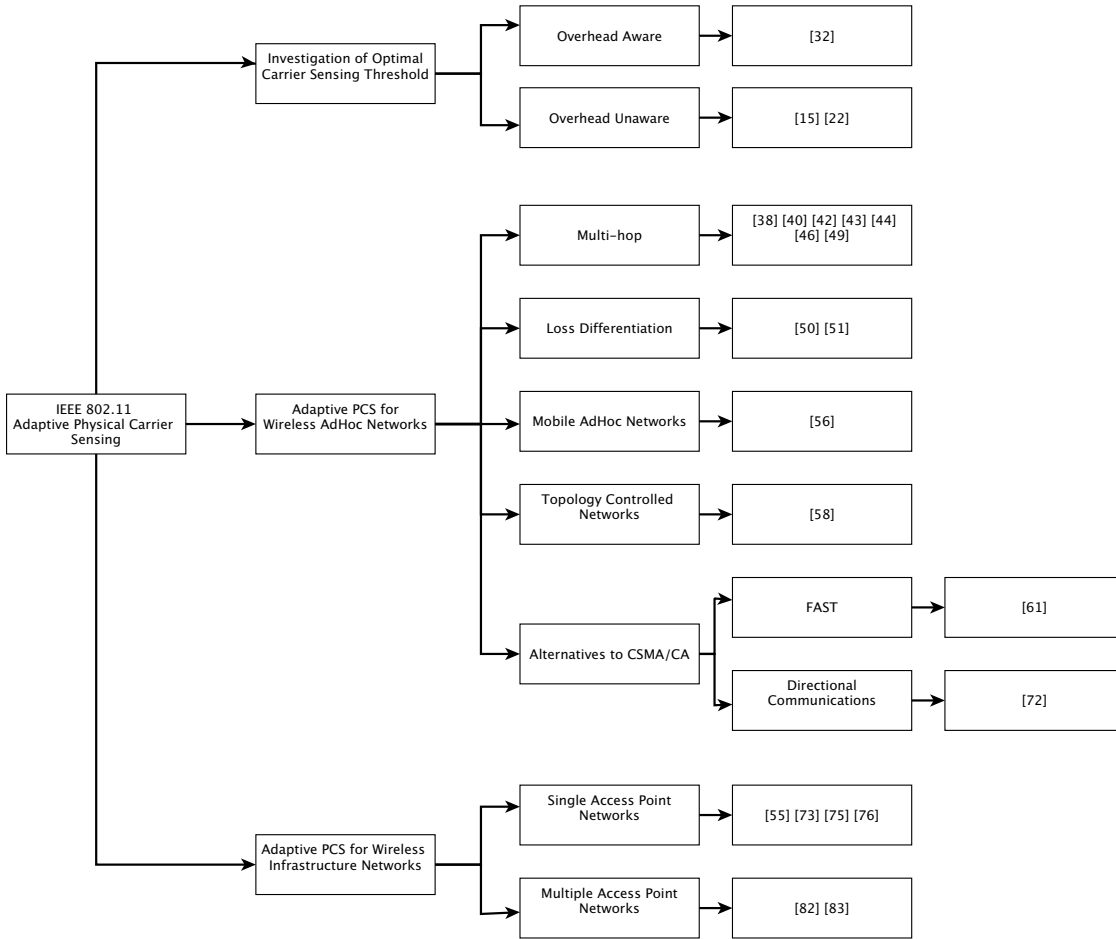

Fig. 11. Structure of Survey

outside the CS region that have not heard the CTS properly may transmit, causing a collision at the receiver. (c) There is a lower probability of successful transmissions with higher node density, due to higher contention.

Further tests were conducted to investigate the optimisation of the PCS range. Observations included: (a) the probability of a successful data packet transmission increases as the PCS range increases; (b) the throughput decreases as the PCS range increased.

The authors plot the optimum PCS range as a function of  $c$  for the simulated scenarios. The results show that the value of optimum PCS range increases with  $c$ , and can vary significantly for different networks. A more accurate correlation of the transmission range, interference model, and PCS range for IEEE 802.11 is necessary to improve performance. Results indicate that an optimally chosen PCS range can improve the performance of a WLAN by increasing the network throughput and decreasing the number of data packet collisions.

### B. A Stochastic Model for Optimising Physical Carrier Sensing and Spatial Reuse in Wireless Ad-hoc Networks

Ma et al. [23] detail an analytical PCS tuning model to investigate the impact of PCST tuning on the throughput and collision rate in a wireless ad-hoc network. The global (used

for all nodes) optimum PCST is computed in advance and remains static for the lifetime of the experiments; it does not adapt in accordance with network dynamics.

The paper presents a stochastic model, to optimize the PCS mechanism and spatial reuse in a network. The work in [24] motivated the proposed model; it details a Markov model developed to determine optimum transmission ranges in multi-hop wireless networks. The PCST was not considered in [24]; therefore, a new Markov model was developed to capture the impact of the PCST and CW size on the one-hop aggregate throughput [23]. Various assumptions were made:

- The majority of collisions are a result of transmissions from hidden nodes; the minority are from simultaneous transmissions.
- The probability of dropping an ACK after successfully receiving a DATA packet is negligible.
- The nodes are positioned according to a 2D poisson distribution with density  $\gamma$  as (6).

The validity of the first two assumptions depends on the contention or sending rate of nodes in the BSS. The higher the sending rate, the higher the probability of simultaneous transmissions or a dropped ACK.

Given an area,  $A$ ,  $P$  is the probability of the number of

nodes,  $N$ , being present in the area.

$$P(N = n) = \frac{\gamma A^n}{n!} e^{-\gamma A}, \quad (6)$$

where,  $e$  is the base of the natural logarithm, and  $n!$  is the factorial of  $n$ .

A 4-state Markov chain is used to model the network in [23]; it is a combination of the 2 models developed in [25] (one for channel status and one for node activity). Figure 12 illustrates the Markov chain, consisting of the four possible states that a wireless channel around a given node can be in at any one time: IDLE, SUCCESS, DEFERRING, and FAIL. The transition probabilities of the chain are computed based on the assumption that all nodes within the transmission range of each other have the same channel status when the channel is IDLE.

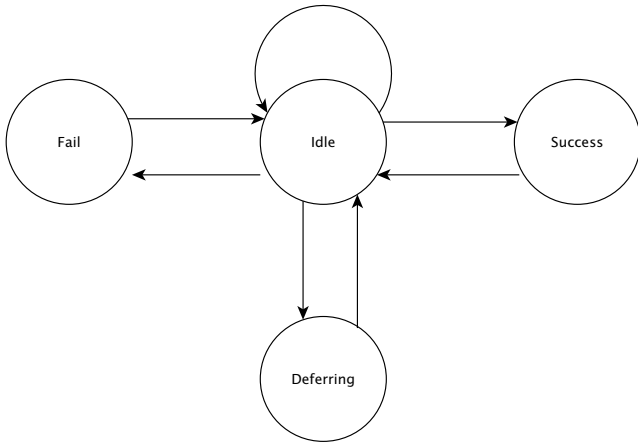

Fig. 12. 4-State Markov Chain

An IDLE state means the channel has been sensed IDLE for a time slot. A SUCCESS state represents a channel that is occupied by a successful transmission (from the node) during the time slot. A FAIL state is indicative of a channel that is busy due to an unsuccessful transmission (from the node) during the time slot. A DEFERRING state means the channel is busy because other nodes in the BSS are transmitting.

Tests were conducted in MATLAB [26] and OPNET simulation tools [27]. The observations of the work in [23] are as follows: As the PCST increases,

- 1) There is a significant increase in the number of transmissions per node per second.
- 2) There is an increase in the number of simultaneous transmissions – due to the shorter PCS range i.e. the nodes back-off less frequently.
- 3) There is a considerable decrease in the rate of successful packet transmissions i.e. as the CS range gets smaller, the number of hidden nodes increases (causing collisions).
- 4) When the aggregate saturation throughput of the network is at the maximum, it indicates an optimum value of the PCST. It is at this point that a balance is reached between the the probability of a collision and the amount of spatial reuse.

Both the analytical and simulation model show very similar results for these experiments. They indicate that a higher throughput per user can be achieved with an aggressive PCST, than a conservative PCST.

### C. On Physical Carrier Sensing in Wireless Ad-hoc Networks

The previously discussed literature assumes a perfect MAC protocol (i.e., no overhead) in the attempt to identify the optimum PCST. The relationship between PCS range and MAC overhead was not investigated. Although this assumption is not realistic or practically achievable, it is a familiar property in the previous literature from this research area. Many studies have been undertaken, in different research fields, to explicitly examine the relationship between the MAC and the PHY layers. Results from these studies [28], [29], [30], [31], [32] highlight the importance of considering the impact of the PHY on the MAC, thus, provide motivation for performing such an investigation in adaptive PCS.

Yang et al. [33] investigate the interactions between Layer 1 and Layer 2. They examine how the MAC overhead influences the choice of optimum PCST, and evaluate its impact on the aggregate system throughput. Both an analytical model and simulation results are used to show that the aggregate network throughput can suffer an enormous loss if MAC overhead is not taken into consideration when calculating the optimum PCST (PCST remains static after calculation).

MAC overhead has been defined in [34]; the definition differentiates between Bandwidth-Independent Overhead (BIO) and Bandwidth-Dependent Overhead (BDO) as follows:

- BIO: When the channel time consumed by overhead is not affected by the bit rate. For example, the IFSSs and back-offs are not influenced by the channel bit rate, therefore, they are classified as BIO.
- BDO: When the channel time used by overhead is affected by the bit rate. For example, the overhead associated with transmission failure are classified as BDO.

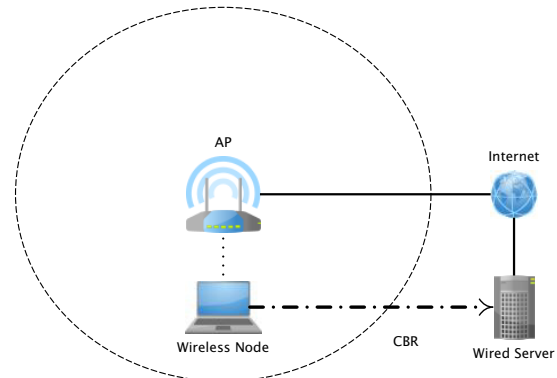

Fig. 13. Channel Load Measurement Test Topology

A key characteristic of BIO is that the percentage of wasted channel capacity increases with the channel bit rate. This finding is echoed in [35], which validates a simulation model of a Channel Load measurement in the QualNet simulation tool [36]. Figure 13 illustrates the topology used to test

the model in [35]. The scenario consists of one wireless node communicating through an AP. The correspondent node is connected through the internet. The wireless node sent Constant Bit Rate (CBR) traffic of 1450 byte packets to the fixed node for 100 seconds. The interval between packets is reduced at different stages to model an increase in channel utilization.

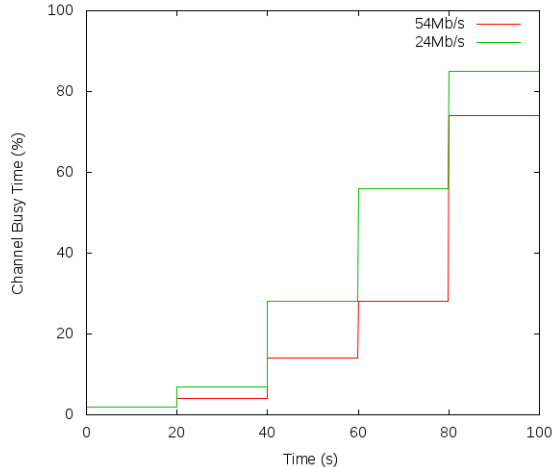

Fig. 14. Channel Load Measurement Throughput Results

The graph in Figure 14 shows the channel load values reported for IEEE 802.11a at 24 Mb/s and 54 Mb/s data rates. When completely saturated the 24 Mb/s test reports a maximum of 85% channel busy time, the 54 Mb/s test reports a maximum of 74% channel busy time. The maximum values are due to the implementation of the channel load report. It does not model the MAC overhead or propagation delay. The max value of the 54 Mb/s test is lower as more frames are sent in this data rate than the 24 Mb/s and thus more overhead is needed.

Correspondingly, the authors in [33] show that a link in a wireless ad-hoc network can use lower bit rates to improve the spatial reuse. Since lower bit rates usually requires less SINR, consequently, more interference can be tolerated at the receiver - more signals can be transmitted concurrently affording greater spatial reuse. Two models are detailed in [33]: a preliminary model, and a more realistic model (that evolved from the early model). The initial analytical model developed in [33] does not consider the MAC overhead in its derivation of the optimum PCST. Given a value for  $SINR$ , the Shannon–Hartley theorem [37] is used to calculate the achievable Channel Rate,  $CR$ , by (7).

$$CR = W \log_2(1 + SINR), \quad (7)$$

where  $W$  is the channel bandwidth, and  $CR$  is measured in bits per second. The Shannon–Hartley theorem states the theoretical tightest upper bound on the information rate (excluding error correcting codes) of clean (or arbitrarily low bit error rate) data that can be sent with a given average signal power through an analog communication channel subject to additive white Gaussian noise is calculated by (7).

Preliminary analysis was performed to determine the maximum achievable aggregate throughput, and to investigate what affect varying the PCST has on this value. The findings from this early work shaped the development of a new model – designed specifically to consider the MAC overhead experienced in IEEE 802.11 communication. Initially only BIO was modeled; further enhancements included BDO. Tests were run in the NS-2 simulation tool to validate the proposed models. Results show that if the PCST is not tuned according to the MAC overhead, the aggregate throughput suffers (degrades by between 15% - 49%).

The authors show that, both BIO and BDO can be reduced by applying a smaller PCST. However, a PCS range that is too small (not sufficiently sensitive) could lead to increased simultaneous transmission, thus increasing overhead. This affects the choice of optimum PCST for wireless ad-hoc networks. The key observations in this work are:

- MAC overhead impacts on the choice of optimum PCST. Applying a larger PCST can lead to a reduction in both BIO and BDO; in addition to an increased spatial reuse.
- The optimum PCST depends on the degree of channel contention, packet size and other network characteristics influencing the overhead. An inappropriate choice of PCST can result in a smaller aggregate throughput.

## V. ADAPTIVE PHYSICAL CARRIER SENSING IN IEEE 802.11 WIRELESS AD HOC NETWORKS

In multi-cell infrastructure-based WLANs, spatial reuse can, in-part, be achieved via effective channel configuration and site planning. However, ad-hoc networks do not have centralized control via APs, therefore, they cannot benefit from such infrastructure planning or the centralized view of the BSS. Consequently, hidden nodes are particularly prevalent in IEEE802.11 wireless ad-hoc networks and WMNs. Moreover, a significant number of studies have shown that VCS is fundamentally limited in mitigating hidden node interference in these architectures [13], [14], [28], [38]. This section describes current adaptive carrier sensing mechanisms and protocols, designed to overcome the deficiencies of the CSMA/CA algorithm in wireless ad-hoc networks. In these networks, fully distributed algorithms are often used to allow each node to self-configure a local optimum PCST based on the channel conditions experienced by the node itself.

### A. Adaptive Physical Carrier Sensing in Multi-Hop Ad-Hoc Networks

In traditional multi-hop ad-hoc networks, the PCST is set to low/sensitive value to defer neighbouring interferers during an ongoing transmission [15], [39], [40]. This low value is close to the noise floor and gives a high probability of a successful transmission, at the cost of reducing spatial reuse. Various mechanisms, which leverage a less sensitive PCST for increasing the performance of of multi-hop ad-hoc networks, are discussed below.

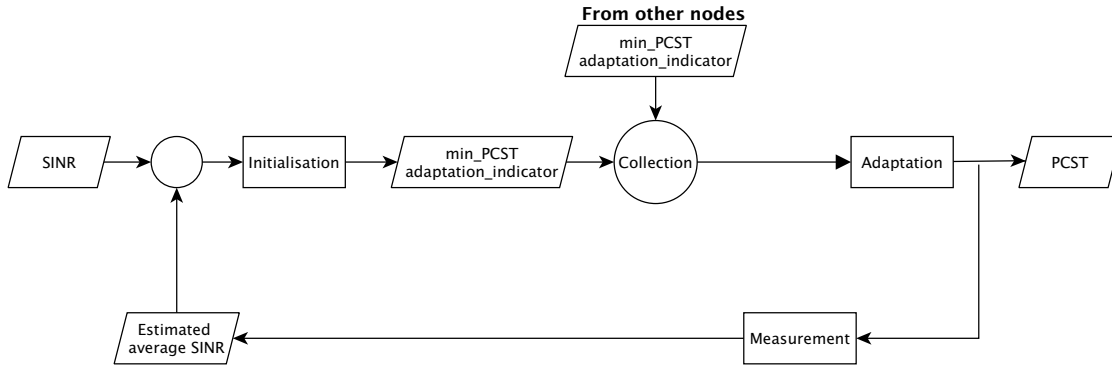

Fig. 15. Feedback Control of the Estimation-Based APCS

1) *Leveraging Spatial Reuse in IEEE 802.11 Mesh Networks with Enhanced Physical Carrier Sensing*: Zhu et al. [41] examine the optimum PCST for various types of ad-hoc networks i.e., a threshold that allows for maximum spatial reuse. The authors determined that the PCST can be tuned to an optimum value (a value that maximizes the system throughput). Based on the results obtained, it is argued that setting the PCST to a value that covers the interference range in its entirety can increase spatial reuse.

An analytical model is presented in [41], to calculate the optimum PCST given network topology, data rate, and receive power. The traditional IEEE 802.11 carrier sensing mechanism is modified to include PCST tuning to increase the rate of spatial reuse in mesh networks, and thus, improve aggregate throughput.

Further work was performed, leveraging the previously proposed analytical model from [41], to develop an adaptive PCST scheme, Adaptive Physical Carrier Sense (APCS) [39]. The distributed adaptation scheme was designed to allow each station to calculate and self-configure the PCST over time, based on current local interference.

The work in [39] assumes a homogeneous network with respect to interference and noise at each node. The aggregate throughput limits were analysed using the model detailed in [42]. The authors in [39] use an analytical model to derive the theoretical estimate for optimum PCST,  $\beta$  (dB), for any given reception power; network topology; and data rate. The main observations of this work are:

- Tuning the PCST to an optimum value can result in increased spatial reuse in IEEE 802.11 mesh networks, without the use of VCS.
- CSMA/CA can effectively employ the spatial-reuse property in a mesh. (90% of the theoretical limit in a chain).
- $\beta = 1/S_0$ , the estimation of the optimum PCST, is sufficient to achieve close-to-optimum performance in chain and grid topologies. Where,  $S_0$  is the SINR requirement.

The model considers only symmetric network topologies consisting of homogeneous nodes. This assumption is the major limitation of the work; it is not accurate for a spatially heterogeneous network.

Figure 15 illustrates the state diagram of the distributed PCST adaptation scheme (APCS) developed in [39]. The target

environment for this model is a dense, indoor, static, ad-hoc mesh network. APCS allows individual stations to determine and configure a near-optimum PCST. The adaptation is based on a periodic estimation of network channel condition. Each node maintains a record of the following parameters:

- The measurement interval, denoted  $T$ .
- The average SINR estimated during a measurement period, denoted  $Avg\_s$ .
- An indicator for adaptation (increase, no change, decrease), denoted  $I$
- Estimation of minimum PCST in the network during a measurement period, denoted  $PCST\_min$ .
- The unit of adjustment after a measurement period, denoted  $a$ .

The objective of the adaptation is to enable nodes, separated by at least minimal possible distance, to transmit simultaneously, while ensuring that SINR does not fall below a defined threshold. The adaptation scheme employed is based on estimation of the network conditions, and is accomplished by local statistics exchange between neighbours. When the mechanism begins, all parameters are initialized. The  $Avg\_s$  and  $PCST$  are only updated once at the end of  $T$ . The values of  $I$  and  $PCST\_min$  are updated whenever an ACK packet is received. All local measurements are disseminated in the neighbourhood (piggybacked with ACK frames). All nodes update  $I$  and  $PCST\_min$  if a smaller value of  $PCST\_min$  is received from a neighbouring node. Each node updates  $PCST$  at the end of  $T$ .

The OPNET simulation tool was used to conduct the experiments. Results show that the overall network throughput can be improved by tuning the PCST: it achieves approximately 90% of the theoretical upper bound predicted by spatial reuse models in a chain topology. In a 4-node chain scenario, three variants of the system were tested. The first had VCS enabled and a default static PCST (CS range = Receive range); the second had VCS disabled and a tunable PCST; the third had VCS enabled and a tunable PCST. Three scenarios were designed, which had intuitively optimum CS ranges set. The systems with the tunable PCST achieve the highest throughput, regardless of VCS being enabled or not. A 440% gain in throughput is achieved over the static default PCST when

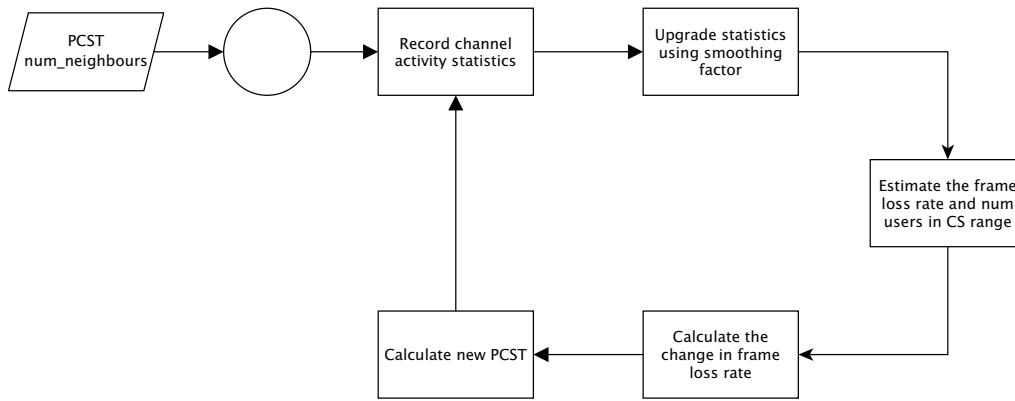

Fig. 16. QoS Heuristic Algorithm

hidden nodes are present in the scenario. The highest aggregate throughput in all three scenarios was between 0.8 - 0.9 Mb/s (optimum throughput is 1 Mb/s).

When the network was scaled up to 90 nodes, the authors measured end-to-end throughput while varying the PCST and the data rate shared by all nodes. The plots of the results show that an optimum PCST exists for each data rate. Significant throughput gains can be achieved by tuning the PCST: 40% for the 1 Mb/s rate; and a 400% for the 11 Mb/s. Similar gains were also seen for a 2D grid network topology.

2) *QoS-aware Adaptive Physical Carrier Sensing for Wireless Networks*: The model in [23] is used by Zhu et al. in [43], [44], and [45] as a basis for their QoS-aware adaptive PCS algorithm. A dynamic tuning technique was developed by Zhu et al., to monitor the statistically significant network performance variations, and to tune the PCST according to these changing conditions. The new proposed model bounds the packet loss in the pre-defined QoS region (specific to particular applications). In the interest of fairness, the authors enforced a global PCST, where all nodes set the same value, rather than a distributed independent PCST tuning. The adaptation can be defined as a change in the PCST over time.

The two main challenges addressed in this work are:

- Construction of a closed-form expression to describe the relationship between the PCST and per-user throughput.
- Dynamic adaptation of the PCST to the varying network conditions.

Two models are presented in [43], [44], and [45]. An analytical model was developed to compute the optimum PCST, and to examine how the aggressive PCS impacts the packet loss rate. A polynomial fit is used by the analytical model to deduce the closed-form expression of the optimum PCST. The algorithm also uses a balance equation, which has the optimum PCST as its root. CSMA/CA measurements (e.g., channel busy and idle times), representing the current network conditions, make up the parameters in the balance equation. This equation is used to heuristically tune the PCST according to the current network conditions and is bounded by the specific QoS requirements.

A key characteristic of the contribution is that, by using a

heuristic approach, it does not involve the complex computation needed to calculate the optimum PCST. Consequently, it is possible to run the algorithm periodically to adapt and improve the performance of the network on-line.

Figure 16 illustrates the adaptive algorithm. When the algorithm begins, the PCST and number of neighbours parameters are initialized. Each node records the channel activity statistics for the duration of a measurement period. These activity statistics are updated with a smoothing factor. The frame loss rate, and number of users in the CS range are estimated. The change in the frame loss rate is calculated, and used to tune the PCST.

Tests were conducted in the NS-2 simulation tool [46]; results show a significance performance gain when compared to the traditional IEEE 802.11 MAC. Three different system variants were tested: the first was traditional IEEE 802.11 PCS without hidden terminals (CS range = interference range); the second was the proposed QoS aware heuristic PCS mechanism; the third was the optimum PCST (calculated with analytical model). The throughput of each variant decreased as the node density increased (as expected). In certain scenarios (with particular data rates and node densities), the QoS PCS mechanism outperformed the variant with no hidden nodes (it can approach the optimum PCST as the PLR corresponding to the optimum PCST is not beyond the QoS requirement of these scenarios). Throughput gains of up to 50% can be achieved by the adaptive PCS, when compared to the traditional IEEE 802.11 mechanism.

3) *Enhancing Spatial Reuse in Ad Hoc networks by Carrier Sensing Adaptation*: Rossetta et al. [47] examine the optimum PCST for wireless ad-hoc networks. An analytical model is presented to show that the optimum PCST is linearly proportional to the node density in a free space path-loss environment. The authors argue that PCST should scale with the intended signal power, defending it as follows: work detailed in [48] highlights that hop distance has a significant impact on the performance of a system; performance is maximized when the distances are smaller. Typically, a dense network consists of neighbours that are, on average, geographically closer to each other, giving shorter hop distances.

The work in [47] presents proof that a global PCST (all nodes have the same PCST) is tightly coupled with node density. Since, selecting an optimum global PCST requires prior knowledge of the node density, a distributed scheme to estimate the local node density was developed (based on [49]). The local PCST is set according to the estimated density using (8), and is adapted over time.

$$PCST = C\hat{n}, \quad (8)$$

where  $\hat{n}$  is the estimated node density and  $C$  is the rate dependent scaling constant.  $C$  was identified by calculating the regression line of the optimum carrier sense density plotted with respect to the node density. For example, using a data rate of 6 Mb/s with free space propagation,  $C$  equals 93 pW/(nodes/hectare).

| Rossetto et al.   | Zhu et al.                                      |
|---|---|
| Uses estimated node density as the basis for adaptation | Uses estimated SINR as the basis for adaptation |
| Does not require information exchange between nodes     | Requires information exchange between nodes     |
| Requires path-loss model information                    | Is not effected by path-loss                    |
| Sets a local PCST                                       | Sets a uniform global PCST                      |

TABLE II  
CONTRAST OF MODELS

The model presented in [47] is based on the previous work by Zhu et al. [39]. The differences between the two are highlighted in Table II. Tests were conducted in a simulation tool; results show a 40% throughput gain, and a 50% reduction in MAC delay, when compared to the traditional IEEE 802.11 MAC and competitive performance when compared to Zhu et al [39].

4) *Throughput Performance in Multi-hop Networks using Adaptive Carrier Sensing Threshold:* Acholem et al. [50] details a quantitative analysis performed that identifies the maximum attainable throughput for chain and grid mesh networks. Several assumptions are made in this work:

- The chain topology contains only one source and one sink node.
- Each node always has a packet to send.
- Fairness is enforced.
- Traffic is uni-directional from source to sink.
- No node mobility.

Results indicate that the optimum value of a common PCST for all nodes in an ad-hoc network is a linear function of node density i.e., the optimum PCST for each topology linearly increases as the number of nodes increases.

A distributed algorithm was developed that included an adaptation scheme to perform local optimization of the PCST over time, based on the current local network density. Each transmitting node,  $N_{tx}$ , estimates the local nodal density,  $\hat{n}$ , based on [47], [49]. Given  $\hat{n}$ , the PCST is equal to  $C\hat{n}$ , where  $C$  is the data rate dependent scaling constant. Throughput results show a 30% improvement when compared to the traditional 802.11 carrier sensing mechanism.

## B. Adaptive Physical Carrier Sensing in Wireless Ad-Hoc Networks with Interference Differentiation

Online measurement of network characteristics is critical to designing an effective adaptive PCS algorithm. The probability of simultaneous transmissions/collisions caused by interference, is an important factor, especially in mesh networks where nodes may start transmitting in the same time slot. Such collisions must be considered in order to maximize aggregate throughput, thus, determining the cause or differentiating between the various types of interference is a key challenge when designing an adaptive PCS algorithm.

1) *CSMA Self-Adaptation based on Interference Differentiation*: Zhu et al. [51] propose a CSMA adaptation which considers the cause of a collision/deferral. They detail various techniques that facilitate the differentiation of WLAN interference types (based on power and timing). Three categories of interference are specified:

- *Exposed Node Interference*: Interference caused by the exposed node problem. Weak signals from exposed nodes will incorrectly prevent a transmission (Figure 17).

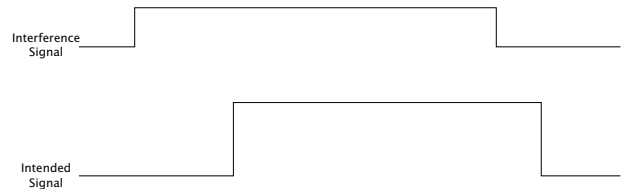

Fig. 17. Exposed Node Interference

- *Simultaneous Transmission Interference*: Two or more nodes initiating a transmission in the same time slot. Higher node density results in higher probability of simultaneous transmissions (Figure 18).

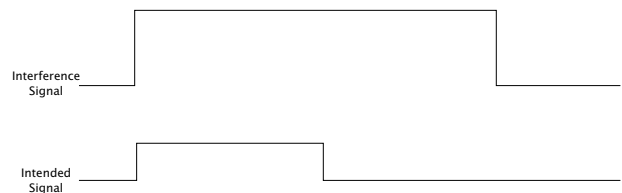

Fig. 18. Simultaneous Transmission Interference

- *Hidden Node Interference*: A hidden node cannot sense an ongoing transmission and initiates an interfering signal transmission (Figure 19).

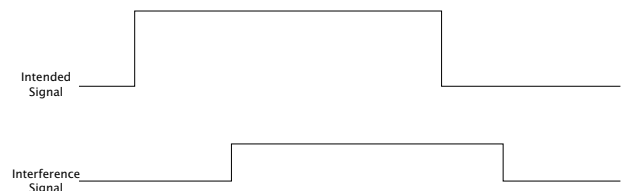

Fig. 19. Hidden Node Interference

The differentiation between the various types of interference facilitates a finer-grained optimization. The individual solutions are detailed in Table III. The adaptive algorithm presented dynamically tunes the PCST and transmit power for exposed and hidden node interferences respectively; the PCST is adapted by each station over time based on the probability of collisions. A lower bound for the PCST was defined to prevent a node from starving i.e never attempting a transmission (a value lower than the noise on the channel would prevent a node ever attempting a transmission as channel would always be evaluated as busy).

The default behaviour of the technique in [51] is to increase the PCST only if there is a very small probability of a collision due to exposed node interference. However, a more aggressive tuning is also discussed, in which the PCST is adapted regardless of the link reliability. Tests were conducted in the OPNET simulation tool for 2-node and multiple node scenarios. Results show a significant performance improvement, achieving almost 100% gain in throughput when compare to traditional IEEE 802.11 MAC.

| Interference Type          | Solution   |
|----------------------------|--|
| Exposed Node               | Tune the PCST to reduce the probability of unnecessary back-offs when signal is likely to be received successfully |
| Simultaneous Transmissions | Tune the CW size to reduce the probability of simultaneous transmissions   |
| Hidden Node                | Tune the transmit power to reduce the probability of a transmission corrupting the an ongoing signal               |

TABLE III  
SOLUTIONS TO MITIGATE INTERFERENCE

2) *Optimizing 802.11 Wireless Mesh Networks Based on Physical Carrier Sensing*: Ma et al. [52] focus on mitigating the negative impact of hidden and exposed nodes in multi-hop, ad-hoc wireless networks. There are three contributions detailed in this article:

- *Analytical Model* - A model to determine the optimum Physical Carrier Sense Threshold (PCST) for homogeneous networks with uniform link distances.
- *Rate Assignment* - A link-distance based rate assignment mechanism is proposed to attempt to equalize the interference range for all links in a non-uniform network.
- *Dynamic Tuning Algorithm* - A dynamic algorithm for online tuning of the PCST, PCSadapt. A key component of PCSadapt is its consideration of the different causes of loss; it differentiates between asynchronous collisions caused by hidden nodes, and synchronous collisions caused by multiple nodes' back-off timers expiring at the same time. The adaptation employed by PCSadapt is a distributed scheme which adapts the PCST over time based on network loss.

*Analytical Model*: An analytical model was developed to optimize the PCST for homogeneous networks, in which several assumptions were made: (a) All nodes use a uniform, constant transmit power, (b) the channel has a deterministic gain and is identical between any two nodes, (c) the distance

between any two nodes and the capacity of all links are identical, (d) the network is homogeneous with respect to spatial uniformity, (e) the network size is sufficiently large so that edge effects can be ignored, and finally (f) hidden and exposed nodes both have the same impact on the network.

If there is a transmitting node,  $N_{tx}$ , and a receiving node,  $N_{rx}$ , there are four possible transmission events of interest:

- 1) *Successful Transmission*:  $N_{tx}$  has a chance to transmit, and the packet will be received at  $N_{rx}$
- 2) *Channel Busy*: The total receive power at  $N_{rx}$  is too high for a packet to be received successfully,  $N_{tx}$  does not transmit.
- 3)  $N_{tx}Hidden$  : The total receive power at  $N_{rx}$  is too high for a packet to be received successfully, but  $N_{tx}$  may attempt a transmission. The packet will be dropped at  $N_{rx}$
- 4)  $N_{txExposed}$  :  $N_{tx}$  does not try to transmit even though a transmission would be successfully received at  $N_{rx}$

The presence of problem nodes in a network can significantly decrease the throughput achieved by a node; the analytical model aims to maximize throughput by minimising the presence of hidden and exposed nodes. The model shows that the optimum PCS range is given by (9).

$$R_{cs} \approx R_I, \quad (9)$$

where  $R_{cs}$  is the PCS range and  $R_I$  is the interference range. Given the distance between nodes, denoted  $D$ , the authors show that the optimum  $R_{cs}$  must lie between  $R_I - D$  and  $R_I + D$ . If  $R_{cs} \geq R_I + D$ , the area of the hidden region will be 0. Increasing  $R_{cs}$  beyond  $R_I + D$  will increase the probability of a problem node. Similarly, if  $R_{cs} \leq R_I - D$ , the area of the exposed region will be 0. Decreasing  $R_{cs}$  below  $R_I - D$  will increase the probability of a problem node. Therefore, the optimum value of  $R_{cs}$  must fall between  $R_I - D$  and  $R_I + D$ . If the value of  $D \ll R_I$ , then the optimum CS range is given by (9).

Experiments show that  $R_{cs} = R_I$  is a robust value for various different network scenarios i.e. the aggregate throughput achieved with this value is typically within 5% and 10% of the throughput from the optimum setting.

The OPNET v.11 model detailed in [53] was used to investigate the effects of modifying the  $R_{cs}$  on the network throughput in various network scenarios. Results indicate that the highest throughput is achieved at almost the same value of  $R_{cs}$  in various different topologies, proving that the analysis remains applicable even when the link density is varied significantly. However, a uniform PCST is only applicable for a network with uniform link distances.

*Rate Assignment*: In a network that is non-uniform with respect to link distances, the SINR can vary considerably between nodes. Correspondingly, it is logical that the PCST should also vary. A link distance based rate assignment mechanism was developed to attempt to equalize the interference range for all links. The motivation for this was to exploit the findings of the analytical model (9). Test were conducted to examine the performance of the default and the optimum PCST. The optimum PCST afforded an increased aggregate

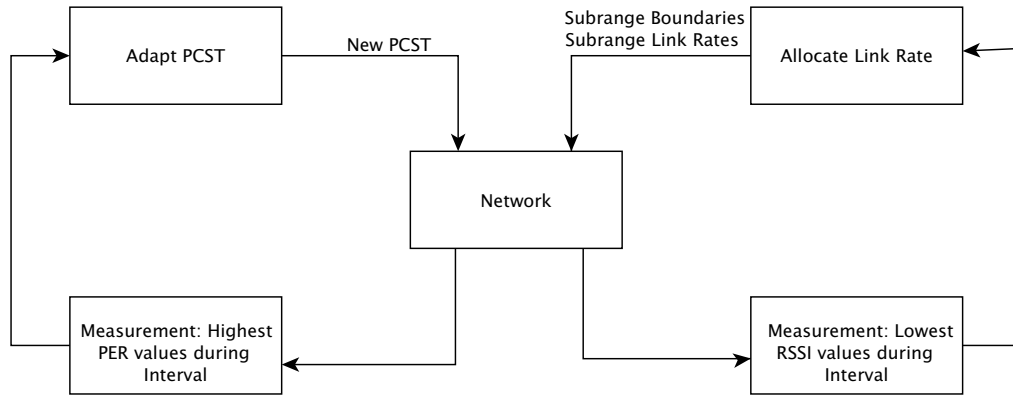

Fig. 20. PCSadapt with Multiple Data Rates

throughput by 86%. The introduction of the rate allocation afforded an additional increase of 34%.

*PCS Adaptation (PCSadapt)*: The adaptation algorithm is based on loss differentiation and builds on the carrier sensing adaptation mechanism first discussed in [54]. The cause of a packet loss is determined using the model in [55] (see Figures 17 - 19). PCSadapt dynamically tunes the PCST while meeting the maximum Packet Error Rate (PER) constraint on each link; it extends the algorithm detailed in [56] (Figure 20). The modification made was to include the differential Packet Loss Rate (PLR) information. The behaviour of PCSadapt can be described as two separate cycles:

- 1) The adaptation cycle – In the beginning of the adaptation cycle, a central entity records all links RSSI values. These values are processed to determine the suitable subrange<sup>4</sup> boundaries, which are then broadcast by the server. All links set their fixed data rate according to these subrange values. During the adaptation cycle, each node measures the per-link PER.
- 2) The operation cycle – The link with the highest PER value is selected to adapt the PCST for the next operation cycle.

Experiments were run in OPNET; the performance of PCSadapt was compared to that of the model in [56] (did not converge). The convergence problem in [56] manifested when decreasing the PCST does not lower the PER caused by collisions (may actually cause it to increase). Consequently, the original model does not identify any value for the PCST to satisfy the PER constraint. The mechanism will continue to adapt, resulting in a very sensitive PCST. The low PCST essentially leads to poor spatial reuse and decreased throughput. PCSadapt overcomes this convergence issue by differentiating between the source of a packet loss; it affords a performance improvement of 159%.

<sup>4</sup>Each link distance is divided into subranges, one for each link rate, in order to equalize the interference range for all links. Since the set of IEEE802.11 link rates is discrete, this can only be achieved approximately.

### C. Adaptive Physical Carrier Sensing in Mobile Ad Hoc Networks (MANETs)

MANETs are self-organising and self-configuring networks operating over radio links. There is no infrastructure present, nodes communicate directly (single-hop) or indirectly (over multiple hops). IEEE 802.11 MANETs operate using CSMA/CA, thus suffer from problem nodes. Often the techniques proposed to mitigate the problem are fully distributed and do not rely on inter-node signaling for tuning the PCST. Instead, nodes monitor the network environment over time to estimate the future channel conditions, and corresponding optimum PCST. Such techniques are more accurate in environments with low mobility, and thus, could be suitable for static or infrastructure mesh networks. Furthermore, increasing the frequency of adaptation or decreasing the measurement period may improve the accuracy of systems with higher mobility (at the cost of increasing overhead).

Benedito et al. [57] details a fully distributed procedure for adapting the PCST for MANET environments. The primary objective of the mechanism is to determine the optimum PCST with regards to maximising the number of successful transmissions (throughput). The adaptation is only performed when (a) a node that has an empty transmission queue receives a packet to transmit, or (b) when a node finishes a transmission and still has other packets to transmit.

The authors propose a set of criteria to determine the optimum PCST:

- A simple model for packet error was developed in [57], which assumes every packet that is successfully transmitted, is successfully acknowledged. If the SINR falls below a specified minimum threshold at any point during the reception, the packet is considered as erroneous.
- A node,  $n$ , chooses a PCST which maximizes the number of on-going successful transmissions completed in the neighbourhood<sup>5</sup>.

Many of the parameters defined in the analytical model are unknown to a transmitting node (e.g. propagation loss of other

<sup>5</sup>The neighbourhood of a node,  $n$ , is defined in the paper as the area given by all the points from which a transmitter would produce a received signal level above the finite upper bound for the PCST

nodes); this results in a high degree of difficulty implementing the specified criteria. A statistical based approach is presented to address this issue. The proposed model assumes that nodes try to maximize the number of successful transmissions in the system. The node,  $n$ , samples a finite range of different PCST values; the PCST that results in the highest average number of successful transmissions is chosen for operation. After collecting  $N$  samples,  $n$  chooses the PCST following the evaluation in (10), with parameters defined in Table IV

$$PCST = \underset{\xi < c \leq PCST_{max}}{\operatorname{argmax}} \frac{1}{K} \sum_{k=1}^K B_k(c) \quad (10)$$

| Symbol       | Definition   |
|--------------|--|
| $\xi$        | Noise floor  |
| $PCST_{max}$ | Finite upper bound for PCST                                    |
| $B_k(c)$     | The number successful transmissions during the $k^{th}$ sample |
| $c$          | The sample PCST value  |

TABLE IV  
PARAMETERS FOR PCST SELECTION

The number of successful transmissions is monitored during a measurement period - it is calculated by tracking the number of ACK packets received by any node in the neighbourhood (1 ACK is equal to 1 successful transmission). Tests were run in a Dartmouth Scalable Simulation Framework based simulation tool [58]. Average throughput gains over multiple different topologies ranged from 11% to 18%, with some topologies achieving an 85% gain.

#### D. Adaptive Physical Carrier Sensing in Topology Controlled Networks

Topology Control (TC) is a term used to describe power control algorithms that are based on the graph notion of a 'neighbour' i.e., two nodes are connected on the graph if they are within transmission range of each other. The main objective of TC is to balance the trade-off between node degree and the connectivity of the graph; the aim is to try to maintain connectivity while keeping the node degree to a minimum. Traditional TC algorithms are limited and do not consider SINR; the values of the PCST is key to resolving this deficiency. The dual concerns of adapting the physical carrier sensing in TC networks results in a highly complex problem. In order to reduce the complexity of the problem, the TC and CS adaptation is separated into a two step approach.

Park et al. [59] detail an approach for overcoming the limitations discussed above. The key motivation for the work is that TC networks may potentially perform worse than uncontrolled networks if the PCST is not set to an appropriate value. A Distributed Carrier Sense Update Algorithm (DCUA) is presented in [59]; it is implemented on each node for local optimization of the PCST (adapted over time).

DUCA is integrated with TC using the previously published Localized Minimal Spanning Tree (LMST) algorithm [60].

The first step is concerned with determining the transmit power,  $p$ , with the aim of maintaining connectivity while minimizing interference. This is a conventional TC problem and is solved with LMST. The next step is to further improve the performance by tuning the PCST.

DCUA is bound by PER to enable a fully distributed algorithm. A penalty,  $P$ , is introduced to ensure nodes behave fairly when tuning the PCST. A quadratic pricing function (11) is employed to penalize a node,  $i$ , for increasing its PCST,  $x_i$ . As the pricing parameter,  $v$ , increases, the nodes are discouraged from increasing the carrier sensing threshold. Low values for  $v$  result in nodes aggressively accessing the channel. Conversely, high values for  $v$  result in a more conservative channel accessing behaviour.

$$P_i(x_i) = v_i x_i^2 / 2 \quad (11)$$

A utility function,  $U$ , is used to indicate the Quality of Service (QoS) level at each node, defined in (12). The main objective is to balance the increase in spatial reuse with the increase in interference. The Packet Error Rate (PER) is used as an indicator of QoS.

$$U_i(x_i, \mathbf{x}_{-i}) := \int_{x_{min}}^{x_i} [q_i^{th} - q_i(\varepsilon, \mathbf{x}_{-i})] d\varepsilon, \quad (12)$$

where  $q_i^{th}$  defines the PER threshold for every node  $i$ , and  $\mathbf{x}_{-i} := (x_1, \dots, x_{i-1}, \dots, x_N)$ .  $q_i$  increases in  $x_i$  for any given  $\mathbf{x}_{-i}$ . The utility function is concave in  $x_i$  and reaches its peak value as the PER reaches the threshold (a configurable parameter that can be configured based on the required QoS for every node).

DCUA optimization operates by trying to minimize  $P$  while maximising  $U$ . Tests were conducted in the J-Sim simulation tool [61]. LMST-DCUA was compared to LMST-CSMA; throughput results indicate that the proposed mechanism achieves a considerable performance improvement, with gains ranging from 24 Mb/s to 34 Mb/s.

#### E. Alternatives to CSMA/CA

1) *Approach for Combating Hidden and Exposed Terminal Problems in Wireless Networks*: Some of the most recent work in this area is presented in [62]. Wang et al. argue that CSMA type protocols are not sufficient for simultaneous resolution of the hidden and exposed node problems. The main reason given for this argument is the lack of accuracy, at reasonable cost, in the channel usage information attainable using CSMA. The authors propose an alternative cross layer approach called Full Duplex Attachment System (FAST), which defines two complimentary parts:

- PHY layer Attachment Coding – used to transmit control information on the wireless channel. The key advantage of this is that it does not impact on the throughput performance of the original data traffic.
- MAC layer Attachment Sense – this leverages the PHY layer control data to identify hidden and exposed nodes in the BSS.

This scheme does not leverage adaptive PCST to address the presence of problem nodes in wireless networks.

A multi-faceted approach is used to validate the work. A model was developed in [62] to preliminarily analyse the feasibility of the proposed scheme. Experiments were conducted to test the scheme on a GNU radio testbed [63]. Finally, simulations were run in NS-3 [64] to evaluate the performance of the scheme in the presence of problem nodes.

**Attachment Coding:** The Attachment Coding (AC) was inspired by the recent research published in the literature on Interference Cancellation (IC) [65], [66]. AC enables extra information to be transmitted without impacting the ongoing data transmission, by carrying out two distinct actions: (1) Attachment modulation and demodulation; and (2) Attachment cancelation and data recovery. AC modulates information into interference-like signals, that are 'attached' to existing data signal transmissions without affecting the decoding process of the original signal. This is facilitated by using IC at the receiver to cancel out the attached signal, such that the original data is recovered.

**Attachment Sense:** Stations in the BSS can leverage these new control signals when determining the channel availability, using a new MAC protocol called Attachment Sense (AS). AS utilizes AC in full duplex to eliminate problem nodes in wireless ad-hoc networks. The authors state a key phenomenon experienced when attempting to solve both hidden and exposed nodes at the same time: The success of a transmission depends only on the channel status at the receiver. Thus they define three actors to describe the behaviour of the AS protocol: A sender, a receiver, and a 'victim'.

AS leverages AC to modulate the identities (hash of MAC address) of each actor into attachment signals. These signals are generated and transmitted under the following rules:

- 1) The transmitter sends attachments and data simultaneously.
- 2) The receiver sends attachments on reception of data packets.
- 3) The 'victim' sends attachments when it is affected by ongoing transmissions.

All nodes in the BSS must maintain two lists (1) Current Transmissions List (CTL), and (2) Neighbourhood Hash List (NHL). The CTL contains fields for the current sender, receiver, and victim, which are filled with the hash of the respective MAC addresses when an attachment is received. The NHL stores encoded addresses for all the one-hop neighbours.

The operation of AS is illustrated in Figure 21. In this example,  $N1$  is transmitting packets to  $N3$ . The attachments from both  $N1$  and  $N3$  indicate that they are the current sender and receiver (illustrated by the green and purple dashed lines respectively). At the same time,  $N4$  is being affected by  $N1$ 's packets, so it also transmits attachments to declare itself as a victim. When  $N2$  has a packet to transmit to  $N4$  or  $N5$  (who has a hash ID of  $H(recv)$ ), it will first listen to attachments on the channel and populate the CTL ( $N1$  as Current Sender (CS),  $N3$  as Current Receiver (CR), and  $N4$  as Current Victim (CV)). Next,  $N2$  will extract NHL from the routing table.  $N2$

will decide whether it can transmit to  $N5$  based on 13

$$(CR \notin NHL) \cap (H(recv)) \notin (CS \cup CV), \quad (13)$$

where the first part of the expression indicates that there are no current receivers within the neighbourhood, and the second part indicates that the intended receiver is available to receive packets (as it is neither a current sender or victim). In the case where  $N2$  wishes to transmit to  $N5$ , (13) will return true: there are no other receivers nearby, and the intended receiver,  $N5$ , is not a sender or a victim. Thus,  $N2$  can transmit to  $N5$  immediately. However, if  $N2$  wishes to transmit to  $N4$ , (13) will return false: Although there are no other receivers nearby,  $N4$  is not able to receive packets. Thus,  $N2$  must defer the transmission and continue to listen for attachments until both conditions are true.

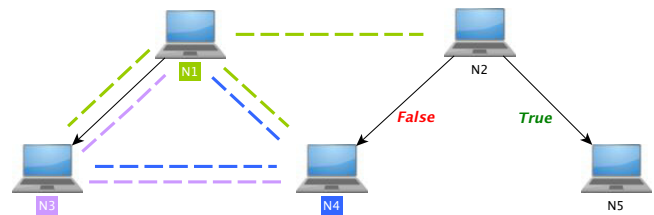

Fig. 21. Attachment Sense

Due to various restrictions in the off-the-shelf hardware used in the testbed, the authors were unable to test the real time throughput performance of the proposed scheme. However, extensive simulations were conducted to test FAST over various different topologies. Results show that by eliminating collisions from hidden nodes and exploiting exposed nodes for spatial reuse (concurrent transmissions), FAST improves per-sender throughput over CSMA between 180% and 200%. When the sending rate is increased, collisions caused by simultaneous transmissions may be unavoidable, resulting in small performance degradation for FAST. However, it still achieves a performance gain of 200% over CSMA/CA.

This work is quite immature and contains several open issues to be considered in future work:

- There is a need to differentiate between the different types of collisions. For example, ACK packets colliding with data packets from exposed nodes (leveraging spatial reuse), and collisions caused by simultaneous transmissions.
- Further investigation is needed to determine the compatibility of full duplex and AC.
- Further analysis is required to evaluate whether a hash value collision could negatively impact on the performance of the system.

Although the work in [62] is preliminary, it has a key advantage over the common estimation-based approaches previously discussed. Since it doesn't rely on monitoring the network locally to try to estimate the global network conditions, it is not subject to the inherent challenges, complexity, and inaccuracies that exist in such an approach.

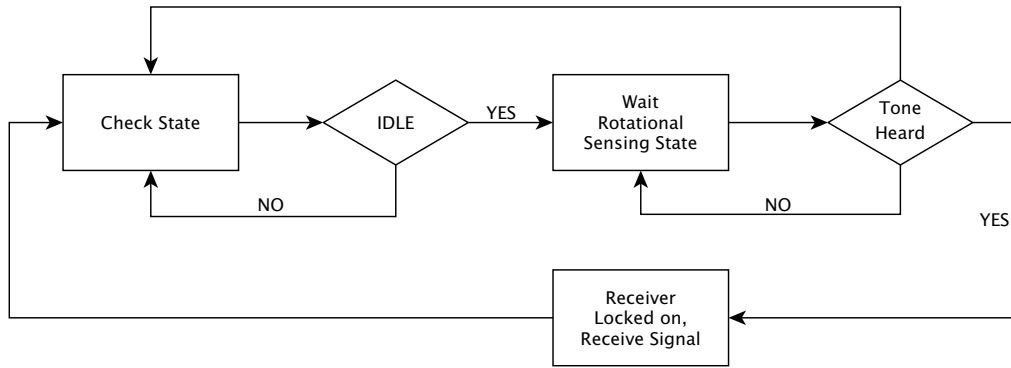

Fig. 22. EDirection State Diagram

2) *Adaptive Physical Carrier Sensing in Ad-hoc Directional Communications*: Omnidirectional antennas are inefficient in terms of spatial reuse. This inefficiency is compounded in ad-hoc architectures, where nodes share a common channel and distant nodes impose a relay load on the network. One alternative that may improve the spatial reuse in ad-hoc networking is to use directional antennas [67], [68], [69], [70], [71]. Most protocols for directional communications rely on the IEEE 802.11 standard, the carrier sensing remains a limiting factor.

In addition to congestion, deafness is also a common cause of transmission failures in directional communications. Deafness is a problem that exists when MAC protocols are designed using Directional Antennae (DA) [72]. It is caused when a communication between transmitter and receiver fails because the receiver is beam-formed towards a different direction (away from the transmitter).

Bordim et al. [73] details a mechanism to improve the performance of the directional MAC protocol; an Adaptive Carrier Sensing (ACS) algorithm, EDirection, is presented and validated with simulation results. The motivation behind the work is to exploit the limitations of DA. In certain circumstances DAs mimic the behaviour of omni-directional antennas, wrongly preventing nodes from transmitting. Two such circumstances include:

- A node wishing to transmit,  $N_{tx}$ , continues to listen to a blocked sector.
- The MAC of  $N_{tx}$  is holding a packet to be sent on a blocked sector.

The goal of EDirection is to prevent  $N_{tx}$  from continuously carrier sensing towards unavailable sectors. The MAC is used to instruct the PHY to listen to unblocked sectors only; the PHY must start listening to the sectors when they become available again. The different approaches detailed in [73] are as follows (illustrated in Figure 22):

- The enhanced DA feature, Angle of Arrival (AoA), uses MAC consultation to determine if a sector is blocked. When the PHY detects an incoming signal, it checks the MAC to see if the current sector is blocked. The PHY cannot lock on to the signal if the sector is blocked, it will continue to sense the medium instead. If a new signal

is detected, the PHY will try to lock on to it to receive it directionally.

- **Directional Carrier Sensing** - The receiving node,  $N_{rx}$ , must perform a  $360^\circ$  scan before a control packet reception. The control packet is modified to include an additional header or tone. When in an IDLE state, nodes wait in a rotational sensing mode. When the tone is heard, the receiver locks on to that sector to receive the incoming signal.
- **Beamwidth Adaptation** - Adapt the beamwidth of a directional antenna to cover all unblocked sectors when consecutive sectors are blocked (see Figure 23). If there are six  $60^\circ$  sectors,  $S_1 \dots S_6$ ,  $S_1$  and  $S_2$  are blocked sectors. The aperture of the beam should be adjusted so that sectors  $S_3 \dots S_6$  can be sensed.
- Using adaptive beamforming, the PHY can selectively avoid listening to NAV sectors on receipt of RTS/CTS packets.

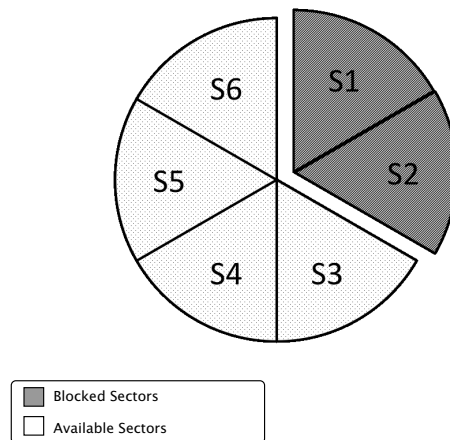

Fig. 23. EDirection Beamwidth Adaptation

EDirection was implemented and tested in the QualNet Simulation tool. Results indicate a significant performance improvement when compared to traditional omni-directional and directional antennas, with a 60% increase in throughput.

## VI. ADAPTIVE PHYSICAL CARRIER SENSING IN IEEE 802.11 INFRASTRUCTURE NETWORKS

Typical IEEE 802.11 infrastructure-based networks consist of one or more APs, each with multiple associated wireless nodes. In a densely populated area, the probability of problem nodes being present increases. This section details the various mechanisms developed to address the limitations of the CSMA/CA algorithm for infrastructure-based networks. Although, infrastructure networks have the potential advantage of site planning and engineering to mitigate problem nodes, however, one of the key factors in the massive penetration of WLANs is the ease of deployment. Very often it is non-experts that configure the WLAN in buildings like small offices or apartment blocks, and generally they start operating on the default channel. This can lead to many separately administered WLANs operating on overlapping channels, resulting in interference limited networks.

The presence of a centralized node in infrastructure WLANs influences the design of the adaptive carrier sensing solutions. The AP has a holistic view of all members of the BSS, and the various network level statistics calculated there can be leveraged in the approaches to optimize the PCST.

### A. Adaptive Physical Carrier Sensing in Single Access Point Systems

The term single AP system is used to reference a wireless system where all AP operate as a single entity i.e., there is no cooperative transmission amongst APs in the system.

1) *IEEE 802.11k enabled Adaptive Carrier Sensing Management Mechanism*: Our work in [74] focused on developing an IEEE 802.11k-enabled adaptive PCS mechanism for wireless networking environments. The PCST is tuned using IEEE 802.11k radio resource management; the main objective is to maximize the throughput of the system. To address the dynamic nature of the WLAN, the network conditions were monitored in time intervals. Using CSMA/CA, each node can sense all transmissions that occur in its PCS range, therefore, they can maintain statistical information on-line.

*IEEE 802.11k*: The IEEE 802.11k is a standard which defines mechanisms for radio resource management [75]. Various measurement request and report frames are specified for use by the upper layers. Radio resource measurements at a node can be carried out in the following ways:

- A node can measure the MAC or PHY layer conditions locally.
- A node can ask another node in the WLAN for a specific measurement to be recored and returned.
- A node may be asked by another node in the WLAN to perform a specific measurement and to transmit the result.

An investigation into the usefulness of these measurements was carried out in [35].

For the work in [74], IEEE 802.11k measurements are employed to calculate several statistics: (a) the channel BUSY time caused by the transmissions of all nodes within the PCS range of the measuring node,  $T_{cs\_range}$ ; and (b) the channel

BUSY time caused by the transmissions of the measuring node only,  $T_{tx}$ . All nodes in the BSS must perform both measurements at periodic intervals; the  $T_{cs\_range}$  is used locally, and  $T_{tx}$  is periodically transmitted to the AP. Every node must maintain a list of the unique IDs identifying all nodes in its reception range, denoted Neighbours List (NL).

A new radio resource measurement and report structure was developed to inform an AP of recent transmission statistics recorded locally. The *Activity Report* is used to report the measurement of channel time taken up by the transmissions of the reporting node. It contains the ID of the node and the transmit time statistic (local measurement), illustrated in Figure 24. Modifications were made to the existing beacon frame to facilitate the broadcast of a list of recent station activity in the BSS. The AP maintains a list of all nodes in the BSS with the corresponding transmit time statistic, denoted the *Station Activity List* (SAL). When the AP receives an activity report from a node in the BSS, it will update the corresponding entry in the SAL.

| Regulatory Class | Channel Number | Actual Measurement Start Time | Measurement Duration | Node ID | Tx Time |
|------------------|----------------|-------------------------------|----------------------|---------|---------|
|                  |                |                               |                      |         |         |

Fig. 24. Activity Report

*K-APCS*: Our initial investigation of adaptive PCS led to the development of K-APCS; a mechanism that uses on-line network statistics (throughput and frame loss) to determine the optimum PCST [76]. Optimising the PCST increases the spatial reuse and maintains an acceptable collision rate by finding a balance between both types of problem nodes. Results show that K-APCS achieved a significant performance gain, however, it increased the unfairness of the system and had some convergence issues.

*KAPCS2*: KAPCS2 was motivated by the limitations of K-APCS [74]. The KAPCS2 tuning algorithm is based on an estimation of whether a wireless station is being effected by the presence of a problem node. It tunes the PCST in time intervals for local optimisation. The presence of problem nodes indicates that the threshold is not optimum, KAPCS2 modifies the PCST until the problem node is eliminated or a good balance between problem and exposed nodes is reached.

Problem nodes can be discovered with a comparison between the elements of the NL and the elements of the SAL. Multiple sets of nodes are defined:

- The set of all nodes in the reception range, denoted  $A$ .
- The set of all nodes in the BSS, denoted  $B$ .
- The set of all nodes outside the reception range (in the PCS range or the hidden region), denoted  $C$ , where  $C = B \setminus A$ .
- The set of exposed nodes within the reception range, denoted  $D$ , where  $D = A \setminus B$ .

The total channel busy time, due to transmissions from nodes outside the reception range is denoted  $T_{cs\_h}$ . It is calculated by summing the  $T_{tx}$  of all nodes in the set  $C$ . Hidden nodes,  $N_h$  are identified by (14), where  $Node_{cs\_h} \in C$ .

$$N_h = (C \neq \emptyset) \wedge (T_{cs\_range} < T_{cs\_h}) \wedge (\exists Node_{cs\_h} \in C (Node_{cs\_h} T_{tx} \leq |T_{cs\_h} - T_{cs\_range}|)) \quad (14)$$

A node can determine if it is a member of an exposed pair/group if it can detect another node that has the characteristics of an exposed node. Exposed nodes are identified by (15)

$$N_e = (D \neq \emptyset) \vee (T_{cs\_range} > T_{cs\_h}) \quad (15)$$

In KAPCS2, the PCST,  $T_{cs}$ , is tuned at time intervals. If a hidden node is discovered, this indicates that the  $T_{cs}$  is not sensitive enough. KAPCS2 attempts to address the insensitivity by decrementing the value of the  $T_{cs}$ . This process is repeated until the node can sense every other node on the BSS. Conversely, if an exposed node is discovered, this indicates that the  $T_{cs}$  is excessively sensitive. KAPCS2 attempts to address this problem by incrementing the values of  $T_{cs}$  in over time until the appropriate sensitivity level is obtained (the node can only sense the transmissions of nodes in the BSS).

Results are presented showing the ability of KAPCS2 to operate across a range of scenarios. The KAPCS2 mechanism affords a substantial gain in throughput: 100% for simple scenarios, and 38% for complex, dynamic, scenarios. PLR is reduced by 83% (simple scenarios), and 23% (complex scenarios), indicating that it is an effective mechanism for tuning the PCST.

2) *Adaptive CSMA for Scalable Network Capacity in High-Density WLAN: a Hardware Prototyping Approach:* Zhu et al. [56] present a hardware prototyping approach to adaptive CSMA for high-density WLANs. The performance of a high-density wireless system is examined. The authors investigate how the throughput is affected by the presence of problem nodes, and by the absence of the capture effect (discussed in section II). The key argument in [56] is that adaptation of the PCST is intrinsic to effectively addressing problem nodes in dynamic networks. A bilateral approach is proposed:

- 1) Receive sensitivity adaptation to reduce the impact of the absence of the capture effect i.e., 'stronger-last' collisions (see Figure 9)
- 2) PCST adaptation to balance the presence of problem nodes in a system

Intel centrino laptops are used for the hardware implementation of the adaptation scheme. Previous work in [39] forms the basis of the proposed algorithms; the simulations employed to test [39] were deemed too simplistic to properly quantify the effectiveness of the proposed algorithm. The authors argue that the majority of the IEEE 802.11 equipment on the market will suffer from stronger-last collisions due to the high cost involved in manufacturing hardware to capture the later, stronger signal.

In [56], PER is used to tune the CCA adaptation; the PCST is bound by maintaining the PER within a target range. The adaptation is illustrated in Figure 25. All stations measure per-link PER during a measurement period. The maximum

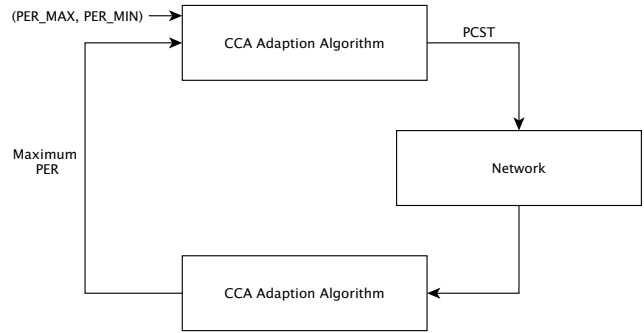

Fig. 25. CCA Adaptation Algorithm

measured PER is used in a linear algorithm to tune the PCST. Tests were conducted using real hardware with UPD traffic. Throughput and fairness were studied and compared to the traditional IEEE 802.11 MAC performance. Throughput gains ranging between 30% and 300% were achieved.

3) *Adaptive Carrier-Sensing for Throughput Improvement in IEEE 802.11 Networks:* Haghani et al. [77] use periodic broadcast signals, from the AP, to facilitate adaptive carrier sensing in IEEE802.11 infrastructure-based networks. This approach dictates that all stations in a BSS must record their BUSY/IDLE (B/I) status during every time slot for a measurement period,  $\Delta$ . Each node generates a binary signal to represent the channel availability during  $\Delta$ , after which, the AP broadcasts its B/I signal to all members of the BSS. This work leverages a B/I signal generation and collision probability estimation techniques that were first published in [78]. Further implementation and demonstration of these models are detailed in [79].

The AP's channel status during a time slot will determine if a packet will be received correctly. Since stations cannot accurately predict the channel status at the AP (due to problem nodes), each node uses both local and received B/I signals when determining the current availability of the channel in [77]. It is necessary for the AP to broadcast this information so that the stations in the BSS can choose their PCST such that the local BI signal mimics that of the AP.

The PCST is tuned in order to minimize the number of time slots in which its problem nodes negatively affect its transmissions [80]. The number of problem nodes affecting each node varies depending on its location, node density of the BSS, etc. Therefore, it is more appropriate to tune the PCST locally for each node. Since the AP broadcasts the B/I signal every  $\Delta$  seconds, correspondingly, each node invokes the adaptive CS algorithm every  $\Delta$  seconds. On receipt of a B/I signal, each station performs an exhaustive search (from a finite set of PCST values), to choose the optimum PCST.

Simulations were conducted in NS-2, results show that over 90% of the stations in the BSS achieved a gain in throughput. The median throughput gain of all nodes is 81%, the average gain was 131%, and the aggregate throughput showed a gain of approximately 50%, whereas the probability of packet loss decreased. The authors investigated the fairness of the

mechanism by plotting the log throughput factor [81]. The graphs show that the log throughput average increases for all scenarios, indicating fair behaviour.

### B. Adaptive Physical Carrier Sensing in Multiple Access Point Systems (MAP)

In recent years, the Multiple AP (MAP) WLAN architecture was proposed; where, wireless nodes can associate with multiple available APs. When a node wants to transmit, they can select the AP with the best quality. Further work has leveraged this multiple association to use Virtual Antenna array (VA) [82] for co-operative transmission in a MAP architecture [83]. However, the introduction of co-operative transmission negatively impacts on spatial reuse due to the simultaneous transmissions of multiple VA nodes. This causes interference to the neighbouring nodes. Adaptive PCS is a potential candidate for solving one part of the problem, however, adaptation of the number of VA nodes is also necessary in providing a complete solution. Given the centralized architecture, the AP is leveraged to access the channel conditions experienced by each node in the BSS and to execute a tuning algorithm.

Hua et al. [83], [84] developed a distributed adaptive PCS mechanism for MAP architecture WLANs. The work includes a joint adaptation scheme for both the PCST and the number of VA nodes. This survey places more emphasis on the PCS adaptation. The PCST is adapted periodically by each AP, and is tuned according to current network conditions. Enhancements to the traditional IEEE 802.11 MAC are detailed, to implement the proposed scheme.

The motivation for using MAP with VA includes the following: The AC is a central entity in a MAP architecture; it has access to all the channel information. This knowledge means it is a prime candidate to make optimum decisions about AP selection. VA is particularly suited to MAP because all relay data can be broadcasted to all VA nodes using wired links, affording a more efficient use of wireless resources. VAs can also be synchronized by the AC.

A system model was developed to investigate the impact of the PCST and the number of VA nodes on the performance of a system. P-Persist is used to model the MAC [10]. The PCST adaptation weighs between the packet loss rate and the number of APs within the PCS range. The model was not accurate for real scenarios (APs are not uniformly distributed in the real world); the theoretical optimum settings are difficult to achieve. A distributed mechanism is needed to tune the PCST.

A dynamic PCS adaptation algorithm based on packet loss rate is detailed. Tuning is based on the premise that the PCST can be increased to promote parallel transmissions if the packet loss rate is low. The AP executes the algorithm periodically. If the measured packet loss crosses the threshold, the adaptation is triggered. Tests were conducted in a discrete time event simulator. Results show a significant throughput gain (values ranging from 17.5 Mb/s to 35 Mb/s) compared to IEEE 802.11 MAC (approximately 5 Mb/s).

## VII. COMPARATIVE ANALYSIS

It is difficult to numerically compare the performance of each of the mechanisms detailed in sections (IV - VI) di-

rectly, due to differences in the: approaches; simulation tools; topologies; and target architecture.

### A. Challenges for Numerical Comparison

1) *Approach*: Some approaches are purely software-based that modify the behaviour of the CSMA/CA algorithm for IEEE 802.11 networks, whereas, some approaches are hardware-based and use directional antennas to improve spatial reuse.

2) *Simulation Models and Configuration*: The performance gains achieved are highly sensitive to the simulation models and configurations. Node density and traffic load affect the contention rate, and thus the collision and throughput values. A higher node density will lead to greater contention, a higher probability of problem nodes being present, a higher collision rate (from both hidden nodes, and simultaneous transmissions), and a lower throughput. The work in [85] shows that the optimum PCST for CSMA/CA is dependent on the design parameters of the system (e.g., distance between a transmitter and its receiver).

NS-2 is a prime example of how a simulation tool can affect the results. It has well known deficiencies in the IEEE 802.11 MAC and PHY models and the architecture. Several publications have shown a lack of accuracy in NS-2's packet reception, and interference models [86], [87], [88]. The tool assesses each interference signal individually to determine if it will interrupt the receiver's current reception or not. This is inaccurate behaviour of the IEEE802.11 PHY; even though a single interference signal may not be strong enough to cause interference, the aggregate interference from other ongoing transmissions may be. This inaccuracy can affect the performance metrics calculated for the network.

The simulation configuration is also very influential to the performance of a system, e.g. the choice of transmission, carrier sensing, and interference ranges may affect the results. Often the choice of these values is dictated by the default settings in the various simulation tools. Values that are frequently generalized, and may not hold true for certain conditions. Caution is needed when selecting values for such ranges.

3) *Topologies*: The topologies used to evaluate the various approaches also impact on the gains achieved. Scenarios with greater numbers of problem nodes on the boundary of a BSS cause aggregate throughput gains to be positively biased. The boundary effect is seen when nodes located at the boundary have a greater opportunity to transmit. If nodes on the boundary are hidden or exposed, they would initially experience high collision rates or low spatial reuse. Following the PCST tuning (which successfully mitigates the problem node), the node on the boundary will experience a higher than normal throughput gain. The complexity (dynamic or mobile scenarios), and the node density also impacts on the performance of a system, all of the approaches surveyed use different simulation scenarios, and node densities.

4) *Architecture*: The various different adaptive PCS techniques are classified in this article based on the target architecture. Each architecture has a specific set of criteria for

| Mechanism | Throughput Gain (%) |
|-----------|---------------------|
| V A(1)    | 40% - 400%          |
| V A(2)    | 50%                 |
| V A(3)    | 40%                 |
| V A(4)    | 30%                 |
| V B(1)    | 100%                |
| V B(2)    | 86% - 159%          |
| V C       | 18% - 85%           |
| V D       | 24% - 34%           |
| V E(1)    | 200%                |
| V E(2)    | 60%                 |
| VI A(1)   | 38% - 100%          |
| VI A(2)   | 30% - 300%          |
| VI A(3)   | 50%                 |
| VI B(1)   | 17.5% - 35%         |

TABLE V  
THROUGHPUT GAIN

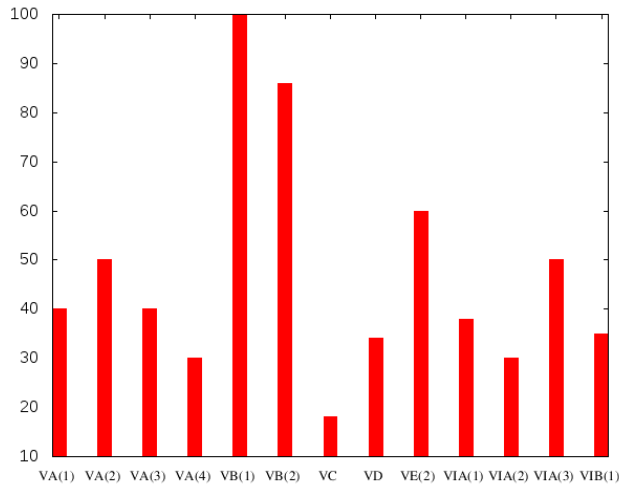

Fig. 26. Throughput Gain (%)

maximising the spatial reuse, and minimising the collision rate. For example, Infrastructure-based approaches detailed in section VI-A1 exploit the centralized control provided by the APs. They leverage the periodic control message exchanges to broadcast the network performance metrics. Such an approach is not applicable for an ad-hoc multi-hop network.

### B. Loose Performance Comparison

Despite the difficulties highlighted in section VII-A, the performance of the proposed approaches can be loosely compared. They all use a common performance metric (throughput), and a common baseline comparison (IEEE 802.11 MAC). Table V details the throughput gains achieved by the adaptive carrier sensing mechanisms in sections IV - VI. It can be noted that generally, the 100% or higher gains are achieved in very simple, small, simulation scenarios (some with low data rates). The lower gains are for larger systems, with higher numbers of non-problematic nodes (these nodes do not directly gain from the PCST adaptation). Figure 26 presents a bar chart of the throughput gain for all mechanisms. It is worth noting that the throughput gains reported in the FAST scheme discussed in section V-E1 are per-node, not system aggregate, therefore are not included in Figure 26.

### C. Advantages/Disadvantages

The performance gains detailed in the surveyed literature are significant; however, throughput may not be the best basis for comparison (due to the challenges discussed in section VII-A). A more appropriate way of comparing the approaches is to discuss their advantages/disadvantages, in terms of: the accuracy of the interference models; the accuracy of the assumptions; and the limitations of the models.

1) *Accuracy of Models:* There are several publications analysing the performance of the IEEE 802.11 MAC DCF protocol [38], [89], [90], [91] (models discussed in sections IV - VI). The majority of these analytical models are based on the Markov chain model proposed in [10]. They are useful in promoting understanding of the theoretical limits of IEEE 802.11 networks, but they are not accurate when severe performance degradation or unfairness is present in a network (as in the case of problem nodes).

Although the topic of this survey has been a hotspot of research activity for almost 10 years, however, the vast majority of the contributions in the literature employ interference models that are either ideal or considerably simplified. As a result, the carrier sensing ranges computed may be sub-optimum and the throughput results positively biased. A comprehensive survey of interference models can be seen in [92].

The work in [15] uses a simplified interference model in which two nodes are considered to interfere with each other if they are within a certain distance from each other. This is not a correct assumption for Non Line Of Sight (NLOS) propagation environments or when multiple nodes are present. Other models with simplifying assumptions include [23], [41], and [33]. The authors of these works use the PCS range as a basis for their analysis. The PCS range translates to the furthest distance at which a node will detect an ongoing transmission, implicitly leading to a complete deferral of all transmission from nodes within the CS region. This is not realistic; typically, the probability of a back-off is affected by the distance of each node from an existing transmission (nodes located nearer are more likely to back-off or defer than nodes further away).

Various models in the literature make unrealistic assumptions regarding the number of interfering nodes in a WLAN. For example, [15], [23], and [41] assume only a single source of interference i.e., only nodes located inside the interference range are taken into consideration, whereas all the interfering nodes located outside the interference range are ignored. Furthermore, [33] assumes a static uniform topology and considers just the 6 closest nodes as origins of interference. Such assumptions are unrealistic and limiting - in practice, a node could experience interference from any number of sources in the network. Moreover, the sum of the weaker interference signals from two or more nodes located beyond the interference range may be strong enough to cause a collision with a transmission in progress. The inaccurate model may result in inaccurate calculation of the network performance, and thus sub-optimum tuning of the PCST or positively biased throughput or collision rate values.

The inverse of an ideal interference model is the worst-case

interference used in [33], [93], and [94], which calculates the worst-case interference that a node could experience (based on the Shannon Capacity). Using this model, only nodes whose distance to the transmitter is equal to the transmission range are considered, and it is assumed that the interfering nodes are always ready to transmit at the desired location (maximum concurrency). This scenario would rarely transpire in real IEEE 802.11 wireless ad-hoc networks. In a random topology, there is only a small probability that nodes are present at precisely the desired location, and successfully contend for the medium to initiate concurrent transmission. The model is based on unrealistic assumptions, leading to inaccurate calculation of network performance, and conservative PCST values and potentially smaller performance gains.

Park et al. [59] propose an adaptive algorithm which employs the PER to tune the PCST. However, the model does not distinguish between the different causes of packet loss (collisions and channel fading). This is limiting as PCST only impacts the collision rate, but not the channel fading. The work in [95] does not make the previously described limiting assumptions. Instead, it attempts to develop a more realistic interference model by computing the aggregate interference from all concurrent transmitters outside the CS range.

Many of the contributions in the literature include analytical models, with some further simulation experiments to provide validation. However, these simulation models may also be inaccurate - there is a known disparity in the quality of radio models implemented in the various different simulation tools available [86], [87], [96], [97], [98].

2) *Accuracy of Assumptions*: The work in [39], [41] assumes a perfect MAC protocol without any overhead when calculating the optimum PCST, leading to an unrealistic and impractical model. MAC overhead is commonly overlooked in most of the previous literature from the area. Many studies, from different research areas, have explicitly examined the relationship between the MAC and the PHY layers. Results in [28], [29], [30], [31], [32] highlight the importance of considering the impact of the PHY on the MAC layer (exposing the inaccuracy of the assumptions in the previous literature).

The results in [33] suggest that a small PCS range would enable more concurrent transmissions. However, they only consider the aggregate interference from the closest 6 interfering nodes (not sufficient for dense networks [42]). Moreover, they make an assumption that all simultaneous transmissions within the PCS range will result in collisions (disproved in [95]).

Zhu et al. [39] argue that setting a global PCST value for all nodes in the WLAN is necessary to support fairness. The goal of their distributed algorithm is to choose the biggest value for the PCST that gives the smallest number of collisions. Results show that the algorithm achieves near optimum results when compared to the analytical model. However, results in [99] indicate that using local optimum PCST can result in throughput performance gains in heterogeneous topologies.

The PCST and SINR threshold are two important issues in IEEE 802.11 MAC, and are considered by the model in [44]. However, this model makes two simplifying assumptions.

Firstly, a RTS transmission will be successful, if the RTS transmission in the first time slot is successful; secondly, if the RTS is received successfully, the following CTS, DATA, and ACK will all be received successfully. These assumptions are not always true in a multi-hop, ad-hoc network suffering from a hidden node problem.

3) *Limitations of Models*: The results in [41] showed that tuning the PCST aggressively can achieve higher throughput (per-user) when compared to a conservative PCST. However, the Markov model used in this work contains some limitations, and the relationship between the throughput and PCST was only represented using a set of expressions (not closed-form solutions). The paper did not discuss the method used for calculating the optimum PCST; it was calculated in advance and was used as a global static value for the entire experiment. This is not ideal for several reasons: firstly, the optimum PCST depends on several properties of the network, which vary over time given the inherently dynamic nature of wireless networks. Hence the value of the optimum PCST will also dynamically change over time in parallel to the varying network conditions (such as the user density, data rates, and traffic load). Secondly, a global common PCST is not sufficient or accurate for a wireless network consisting of heterogeneous links.

The heuristic algorithms detailed in [55] and [56] are centralized algorithms for adjusting the PCST (based on the network performance), which can not be implemented in distributed ad hoc networks. [39], [59], and [100] proposed distributed adaptive mechanisms to dynamically adapt the PCST to reduce the probability of collisions from hidden nodes in order to enhance spatial reuse. However, these mechanisms did not consider the delay problems of exposed nodes. Neither do they differentiate between the nodes located in different regions (carrier sensing/interference region). The solutions proposed in the [39], [55], and [56] give local results, or are purely localized (a node tunes its PCST with no consideration of the impact on the rest of the network). In addition, not all of the methods distinguish between collisions from simultaneous transmission, and those from hidden nodes. This can lead to suboptimal behaviour, where the PCST is wrongly decreased (having a negative impact on performance).

The authors in [85] argue that to minimize the probability of a collision, the transmitters senders must ensure that the product of the transmit power and PCST equals a specified fixed constant value. Since this is a centralized algorithm, it depends on the accurate estimation of the RSSI. The authors proposed a second algorithm in [85], that is distributed, to overcome this limitation. Using [85], every node selects the PCST that gives the maximum number of successful transmissions in the neighbourhood. The drawback of this mechanism is that it needs to collect information from the network during a measurement period. This algorithm is complex, and it is not able to handle rapid interference variations.

The model in [23] only considers the hidden node problem, and does not consider the exposed node problem. Although the hidden node problem is significant (affecting the collision probability), the exposed node problem also needs careful consideration as it is closely related to the level of spatial

reuse. The models in [23] and [33] also assume single data rates. Typically, real IEEE 802.11 networks consist of multiple nodes transmitting using varying data rates (depending on distance from the receiver).

Zhu et al. [56] built a testbed using Intel PRO/Wireless 2200 MiniPCI cards. They ran experiments to examine the affect of an aggressive PCST on per-user throughput. In addition, they investigated the efficacy of a joint PCST and Receive-Sensitivity adaptation in balancing the problem nodes and mitigating stronger-last collisions respectively. However, since they did not analyse the optimisation of the PCST, the proposed mechanism cannot determine the optimum PCST. They simply tune it to bound the frame loss rate in a given region. Moreover, the technique has suboptimal behavior in uncoordinated environments.

The results in [44] show that when the PCS range equals the interference range, the aggregate network throughput can reach the maximum. This is true only in homogenous network topologies, with regular node distribution. The algorithm proposed in [101], for tuning the PCST of random network topologies, could be used to overcome such a limitation. However, it is a centralized algorithm, and the rules to tune the PCST are based on the transmission condition at a fixed transmission rate. Results show that different set of transmission rates and PCSTs may lead to different aggregate throughput. Therefore, only tuning the PCST can not attain the maximum aggregate network throughput.

The model in [76] optimized the PCST value to enable increased channel utilisation with acceptable collision rates. Although results show a considerable throughput gain and packet loss reduction, K-APCS was limited with regards to convergence and fairness. The algorithm did not converge, and oscillated around the optimum PCST. Also, nodes in the system suffered from a lack of fairness: some nodes were starved of transmission opportunities, while other monopolized the medium. KAPCS2 [74] was motivated by the limitations of K-APCS [76]. It introduce a new defer state to prevent oscillation (a node will defer PCST tuning in certain cases). The behaviour of the mechanism is not optimal for certain scenarios.

Cooperative systems [83], [84] share received signals to achieve a good spatial reuse and location accuracy. However, they require that receivers must synchronize their symbols (achieved by transmitting pilot symbols). This can be a complex and bandwidth wasting exercise, particularly in broadcast systems.

The deficiencies of the algorithms which do not differentiate between the source of interference can be demonstrated by the following example (using Figure 6 as a reference):  $n_{tx}$  is transmitting to  $n_{rx}$ ,  $n_h$  and  $n_{tx}$  are a hidden pair, and  $n_e$  is an exposed node that is located in the region where the interference region of  $n_{rx}$ , and the carrier sensing region of  $n_{tx}$  intersect. Given that collisions/interference can be classified into three separate types:

- 1) Collision - Type1: Node  $n_{tx}$  can't sense an ongoing transmission (from  $n_h$ ) and transmits to  $n_{rx}$ , a collision occurs.
- 2) Collision - Type2: Node  $n_{tx}$  is transmitting to  $n_{rx}$ , node

$n_h$  can't sense the ongoing transmission and starts to transmit, a collision occurs.

- 3) Collision - Type3: Node  $n_h$  and node  $n_{rx}$  start to transmit simultaneously, a collision occurs.

The algorithms in [39], [55], and [56] can anticipate and prevent type 1 collisions, but they cannot address the hidden terminal that results from type 2. If  $n_h$  initializes a transmission (after  $n_{tx}$ ), and disrupts the ongoing transmission, the algorithms suggest that  $n_{tx}$  should decrease the PCST in response to a transmission failure. However, node  $n_h$  will increase the PCST, unaware that the transmission has corrupted that of  $n_{tx}$ . This behaviour leads to  $n_{tx}$  retransmitting, and  $n_h$  will still continue to sense an IDLE channel status and proceed to start a new transmission. Node  $n_h$  will continue to increase its PCST for resulting transmissions, and it will transmit more competitively. Therefore any transmission from node  $n_h$  will always disrupt that of node  $n_{tx}$ , leading to  $n_{tx}$  repeatedly decreasing its PCST (until its chance of transmitting is lost). Thus exhibiting unfairness between nodes.

4) *Complexity*: Modeling the performance of the IEEE 802.11 MAC involves a high level of complexity. There are several key characteristics that contribute to this:

- The media is shared and has a limited connection range.
- The radio is significantly less reliable than cable, leading to higher error rates caused by interference and non-stationary multi-path fading.
- The presence of problem nodes and capture effect.

Further, aggregate network throughput is a function of multiple factors, including:

- The topology of the network in terms of distance between nodes, and the density of nodes.
- The data rate of the links.
- The size of the CW.
- The traffic pattern in terms of flow and load.

Each of these factors add to the interference experienced by nodes in the network. Examining them all is extremely complex and infeasible; therefore many researchers only focus on a subset of them.

Much of the surveyed literature uses analytical models to estimate the performance of the network. These models are typically simplified in order to reduce the complexity of the algorithms. For example, the authors in [39] employ a simplified fading model in their work to decrease the complexity of the simulation, and to increase the speed. Usually, fading should be finely grained (a random value chosen every millisecond), however, the authors employ a packet level energy calculation to simulate lognormal fading channel. The authors in [54] simplify their model by reducing the set of available data rates from 8 to 4, this results in a small performance loss, but a huge reduction in the complexity of discovering the jointly optimum set of PCST values for any network.

In addition to this, heuristic algorithms are used as a compromise; they find an approximate solution instead of an exact solution to reduce the complexity.

Often increasing the granularity of an existing algorithm will have the effect of increasing the complexity and cost of the mechanism. The authors in [57] present an improved,

finer-grained, carrier sensing adaptation algorithm (based on [85]). Each node selects the PCST that maximizes the number of successful transmissions in its neighbourhood (rather than a local optimisation with no consideration of the impact to the neighbouring nodes). This approach however, relies on network monitoring to gather statistics over time intervals, which introduces signaling overhead, higher complexity and delays.

Common methods of reducing the complexity of the models is to make simplifying assumptions, such as homogenous nodes and links, single data rates, and regular grid or chain topologies. Additionally, a global PCST can be used to simplify the mechanisms detailed in literature. Another complexity/performance trade-off that can be balanced is performing online dynamic tuning of the PCST. Wireless networks are inherently dynamic in nature. Since the optimum PCST is calculated based on network conditions (which change dynamically), therefore, it is logical that tuning the PCST should be done dynamically. However, this approach adds to the complexity and cost of running the scheme.

The adaptive mechanisms which require message exchanges amongst nodes in the neighbourhood (e.g., [74], [76]) have the additional signaling overhead of reporting the metrics over the radio channel. The frequency and size of the reports will have an impact on the available bandwidth. Finally, the cost and complexity of antenna system implementation [73] depends on many factors including the number of antenna elements and the beam-forming algorithm.

#### *D. Alternative Approaches for Spatial Reuse*

Since the radio is a shared medium (all nodes have the same collision/broadcast domain), the range of the collision domain is a function of two important factors: the PCST and the transmit power used by each node. This survey has discussed in great detail how dynamically tuning the PCST can increase the spatial reuse in an IEEE 802.11 WLAN, however, it has not explored the effect of adapting the transmit power (which can also improve spatial reuse).

The work in [94], presents a comprehensive study of improving spatial reuse by tuning the PCST, transmit power, and data rate in multi-hop WLANs. [85] and [94] examine the relationship between the PCST and the transmit power. [94] quantifies the trade-off between the increased spatial reuse and the reduced data rate that each node can use successfully. They present an analytical framework to determine the optimum range of transmit power/PCST in which the network capacity is maximized.

Power control has been investigated for topology maintenance [102], [103], [104], and [105]. The PCMA [106], the PCDC [107], and the POWMAC [108] protocols first considered power control for spatial reuse. However, none of these protocols considered the effect that the PCST has on the network throughput. The work in [109] addresses the issue of tuning the data rate and the transmit power together, for high density WLANs to reduce interference and maximize throughput.

There are also other alternative adaptive mechanisms proposed to enhance spatial reuse in IEEE 802.11 networks.

Researchers have modified both temporal and spatial aspects of the standard to achieve improvement in performance. Other mechanisms include adapting the CW, and data rates. The authors of [6] present an extensive survey of the literature which attempts to improve spatial reuse in multi-hop wireless networks. These alternative mechanisms should also be evaluated when trying to address poor performance of IEEE WLANs.

## VIII. FUTURE DIRECTIONS

This area remains an important research topic, requiring more effort to bring about a resolution. The previous analytical modeling has provided a good insight into the potential achievable performance gains. The contributions to date have leveraged CSMA/CA parameter adaptation to exploit some performance improvement, however, some of the work is incomplete. The proposed schemes contain various limiting features which need to be addressed. For example all of the models make various assumptions which are not always realistic. i.e assumptions about uniform distribution of nodes, uniform data rates etc. The accuracy of the models is questionable, and limitations have been highlighted by the authors. Imperfect or unrealistic models lead to positively biased results.

Due to the difficulty in accurately modeling the IEEE 802.11 MAC, it may be more useful for the mechanisms presented to be implemented in hardware and tested in a lab testbed environment to validate their efficacy. The authors in [17] argue that experimental testing is of upmost importance when evaluating mechanisms that estimate the quality of radio links. They conclude that it is extremely difficult to capture 'real' wireless network behaviour in simulations, and that issues such as complex radio propagation effects, real antenna behaviour, front-end amplifier problems, etc. (if modeled incorrectly) can all affect the performance of a wireless system. In addition, experimental testing also highlights implementation issues, demonstrates the practicality of mechanisms on real hardware, and helps to build confidence in the proposed approach.

## IX. CONCLUSION

This article presented a survey of the literature on adaptive carrier sensing mechanisms for IEEE 802.11 networks, from the inception of the topic to the current state of the art. A significant amount of effort has been invested in this space from the research community, consequently, there has been a substantial number of works published in both conference proceedings and journals.

The area has developed considerably since the first contributions investigating an optimum PCST. Further evaluation of this concept was facilitated with the use of analytical models, which examined how tuning this value would impact on the network performance. Preliminary results indicated that changing the PCST afforded huge aggregate throughput gains for different systems. Thus, mechanisms to calculate the optimum PCST for wireless networks were developed. The optimum PCST value that maximizes system throughput is

tightly coupled with network conditions. The inherent dynamic nature of wireless networks drove the research in a dynamic, online, adaptive direction. The mechanisms employed online tracking of network conditions; the PCST was dynamically tuned according to the network status. Dynamic adaptation schemes have achieved near optimum results in some instances.

As discussed in section VII-A, it is very difficult to directly compare the performance of each mechanism discussed. Such a comparison would require substantial effort to implement and simulate each one using common scenarios (within architecture category), and is out of the scope of this survey. However, possible future work could include a comprehensive simulation comparative analysis.

#### ACKNOWLEDGMENT

This research is supported, in part, by Science Foundation Ireland (SFI) via grant 08/SRC/I1403 FAME SRC (Federated, Autonomic Management of End-to-End Communications Services - Strategic Research Cluster, and in part, by Science Foundation Ireland grant 10/CE/I1855 to Lero - the Irish Software Engineering Research Centre ([www.lero.ie](http://www.lero.ie))

#### REFERENCES

- [1] M. Borgo, A. Zanella, P. Bisaglia, and S. Merlin, "Analysis of the hidden terminal effect in multi-rate IEEE 802.11b networks," in *Proc. of the 4th International Symposium on Wireless Personal Multimedia Communications (WPMC 2004)*, 2004.
- [2] A. Jayasuriya, S. Perreau, A. Dadej, and S. Gordon, "Hidden Vs. exposed terminal problem in ad-hoc networks," in *Proc. of the 5th Australian Telecommunication Networks and Applications Conference (ATNAC 2004)*, 2004.
- [3] A. Rahman and P. Gburzynski, "Hidden problems with the hidden node problem," in *Proc. of the 23rd IEEE Biennial Symposium on Communications (QBSC 2006)*. IEEE, 2006, pp. 270–273.
- [4] P. Ng, S. Liew, K. Sha, and W. To, "Experimental study of hidden node problem in IEEE 802.11 wireless networks," *ACM Special Interest Group on Data Communication - Poster (SIGCOMM 2005)*, 2005.
- [5] S. Xu and T. Saadawi, "Revealing the problems with 802.11 medium access control protocol in multi-hop wireless ad hoc networks," *Elsevier Journal on Computer Networks*, vol. 38, no. 4, pp. 531–548, 2002.
- [6] B. Alawieh, Y. Zhang, C. Assi, and H. Mouftah, "Improving spatial reuse in multihop wireless networks - a survey," *IEEE Communications Surveys & Tutorials*, vol. 11, no. 3, pp. 71–91, 2009.
- [7] I. Aad and C. Castelluccia, "Differentiation mechanisms for IEEE 802.11," in *Proc. of the 20th Annual Joint Conference of the IEEE Computer and Communications Societies (INFOCOM 2001)*, vol. 1. IEEE, 2001, pp. 209–218.
- [8] "Part 11: Wireless LAN medium access control (MAC) and physical layer specification."
- [9] D. Bantz and F. Bauchot, "Wireless lan design alternatives," *IEEE Network Magazine*, vol. 8, no. 2, pp. 43–53, 1994.
- [10] G. Bianchi, "Performance analysis of the IEEE 802.11 distributed coordination function," *IEEE Journal on Selected Areas in Communications*, vol. 18, no. 3, pp. 535–547, 2000.
- [11] T. Ho and K. Chen, "Performance analysis of IEEE 802.11 CSMA/CA medium access control protocol," in *Proc. of the 7th IEEE International Symposium on Personal, Indoor and Mobile Radio Communications (PIMRC 1996)*, vol. 2. IEEE, 1996, pp. 407–411.
- [12] A. Tanenbaum, "Computer networks," *Prentice Hall, Fourth Edition*, vol. 1, p. 6, 2003.
- [13] K. Xu, M. Gerla, and S. Bae, "How effective is the IEEE 802.11 RTS/CTS handshake in ad hoc networks?" in *Proc. of the IEEE Global Telecommunications Conference (GLOBECOM 2002)*, vol. 1. IEEE, 2002, pp. 72–76.
- [14] F. Ye, S. Yi, and B. Sikdar, "Improving spatial reuse of IEEE 802.11 based ad hoc networks," in *Proc. of the IEEE Global Telecommunications Conference (GLOBECOM 2003)*, vol. 2. IEEE, 2003, pp. 1013–1017.
- [15] J. Deng, B. Liang, and P. Varshney, "Tuning the carrier sensing range of IEEE 802.11 MAC," in *Proc. of the IEEE Global Telecommunications Conference (GLOBECOM 2004)*, vol. 5. IEEE, 2004, pp. 2987–2991.
- [16] G. Anastasi, E. Borgia, M. Conti, and E. Gregori, "Wi-fi in ad hoc mode: a measurement study," in *Proc. of the 2nd IEEE Annual Conference on Pervasive Computing and Communications (PERCOM 2004)*. IEEE, 2004, pp. 145–154.
- [17] D. Giustiniano, D. Malone, D. J. Leith, and K. Papagiannaki, "Measuring transmission opportunities in 802.11 links," *IEEE/ACM Transactions on Networking (TON)*, vol. 18, no. 5, pp. 1516–1529, 2010.
- [18] K. Whitehouse, A. Woo, F. Jiang, J. Polastre, and D. Culler, "Exploiting the capture effect for collision detection and recovery," in *Proc. of the 2nd IEEE Workshop on Embedded Networked Sensors (EmNetS-II 2005)*. IEEE, 2005, pp. 45–52.
- [19] M. Conti, J. Crowcroft, and A. Passarella, *Multi-hop ad hoc networks from theory to reality*. Nova Science Pub Inc, 2007.
- [20] Draft Standard for Information Technology - Telecommunications and Information Exchange Between Systems - LAN/MAN Specific Requirements - Part 11: Wireless Medium Access Control (MAC) and Physical Layer (PHY) specifications: Amendment 10: Mesh Networks Std.
- [21] S. Faccin, C. Wijting, J. Kenckt, and A. Damle, "Mesh WLAN networks: concept and system design," *IEEE Wireless Communications*, vol. 13, no. 2, pp. 10–17, 2006.
- [22] Y. Zhu, Q. Zhang, Z. Niu, and J. Zhu, "Leveraging multi-AP diversity for transmission resilience in wireless networks: architecture and performance analysis," *IEEE Transactions on Wireless Communications*, vol. 8, no. 10, pp. 5030–5040, 2009.
- [23] H. Ma, H. Alazemi, and S. Roy, "A stochastic model for optimizing physical carrier sensing and spatial reuse in wireless ad hoc networks," in *Proc. of the 2nd IEEE International Conference on Mobile Ad Hoc and Sensor Systems Conference (MASS 2005)*. IEEE, 2005, pp. 8–pp.
- [24] H. Takagi and L. Kleinrock, "Optimal transmission ranges for randomly distributed packet radio terminals," *IEEE Transactions on Communications*, vol. 32, no. 3, pp. 246–257, 1984.
- [25] L. Wu and P. Varshney, "Performance analysis of CSMA and BTMA protocols in multihop networks (i). single channel case," *Elsevier Journal on Information Sciences*, vol. 120, no. 1, pp. 159–177, 1999.
- [26] "Matlab simulation tool," <http://www.mathworks.co.uk/products/matlab/>, February 2014.
- [27] "Opnet simulation tool," <http://www.opnet.com>, February 2014.
- [28] Z. Li, S. Nandi, and A. Gupta, "Improving fairness in IEEE 802.11 based MANETs using enhanced carrier sensing," in *IEEE Proceedings - Networking*, vol. 151, no. 5. IEEE, 2004, pp. 467–472.
- [29] G. Holland, N. Vaidya, and P. Bahl, "A rate-adaptive MAC protocol for multi-hop wireless networks," in *Proc. of the 7th Annual International Conference on Mobile Computing and Networking (MOBICOM 2001)*. ACM, 2001, pp. 236–251.
- [30] B. Sadeghi, V. Kanodia, A. Sabharwal, and E. Knightly, "Opportunistic media access for multirate ad hoc networks," in *Proc. of the 8th Annual International Conference on Mobile Computing and Networking (MOBICOM 2002)*. ACM, 2002, pp. 24–35.
- [31] S. Gobriel, R. Melhem, and D. Mossé, "A unified interference-collision analysis for power-aware adhoc networks," in *Proc. of the 23rd IEEE Annual Joint Conference of the IEEE Computer and Communications Societies (INFOCOM 2004)*, vol. 1. IEEE, 2004.
- [32] M. Carvalho and J. Garcia-Luna-Aceves, "A scalable model for channel access protocols in multihop ad hoc networks," in *Proc. of the 10th Annual International Conference on Mobile Computing and Networking (MOBICOM 2004)*. ACM, 2004, pp. 330–344.
- [33] X. Yang and N. Vaidya, "On physical carrier sensing in wireless ad hoc networks," in *Proc. of the 24th Annual Joint Conference of the IEEE Computer and Communications Societies (INFOCOM 2005)*, vol. 4. IEEE, 2005, pp. 2525–2535.
- [34] T. Todd and J. Mark, "Capacity allocation in multiple access networks," *IEEE Transactions on Communications*, vol. 33, no. 11, pp. 1224–1226, 1985.
- [35] C. Thorpe, S. Murphy, and L. Murphy, "Analysis of variation in IEEE 802.11k channel load measurements for neighbouring WLAN systems," in *Proc. of the 17th ICT Mobile and Wireless Communications Summit (ICT-MobileSummit 2008)*, 2008.
- [36] "Qualnet simulation tool," <http://www.scalable-networks.com>, February 2014.

- [37] R. V. L. Hartley, "Transmission of information," *Bell System Technical Journal*, vol. 7, no. 3, pp. 535–563, 1928.
- [38] S. Xu and T. Saadawi, "Does the IEEE 802.11 MAC protocol work well in multihop wireless ad hoc networks?" *Communications Magazine, IEEE*, vol. 39, no. 6, pp. 130–137, 2001.
- [39] J. Zhu, X. Guo, L. Lily Yang, W. Steven Conner, S. Roy, and M. Hazra, "Adapting physical carrier sensing to maximize spatial reuse in 802.11 mesh networks," *Wiley Online Journal on Wireless Communications and Mobile Computing*, vol. 4, no. 8, pp. 933–946, 2004.
- [40] K. Jamieson, B. Hull, A. Miu, and H. Balakrishnan, "Understanding the real-world performance of carrier sense," in *Proc. of the 2005 ACM SIGCOMM workshop on Experimental approaches to wireless network design and analysis*. ACM, 2005, pp. 52–57.
- [41] J. Zhu, X. Guo, L. Yang, and W. Conner, "Leveraging spatial reuse in 802.11 mesh networks with enhanced physical carrier sensing," in *Proc. of the IEEE International Conference on Communications (ICC 2004)*, vol. 7. IEEE, 2004, pp. 4004–4011.
- [42] X. Guo, S. Roy, and W. S. Conner, "Spatial reuse in wireless ad-hoc networks," in *Vehicular Technology Conference, 2003. VTC 2003-Fall. 2003 IEEE 58th*, vol. 3. IEEE, 2003, pp. 1437–1442.
- [43] Y. Zhu, Q. Zhang, Z. Niu, and J. Zhu, "QoS-aware adaptive physical carrier sensing for wireless networks," in *Proc. of the IEEE Wireless Communications and Networking Conference (WCNC 2007)*. IEEE, 2007, pp. 2311–2316.
- [44] —, "On optimal physical carrier sensing: theoretical analysis and protocol design," in *Proc. of the 26th IEEE International Conference on Computer Communications (INFOCOM 2007)*. IEEE, 2007, pp. 2351–2355.
- [45] Z. Y. Z. Q. N. Z. and Z. J., "On optimal physical carrier sensing for IEEE 802.11 based WLANs: Theoretical analysis and protocol design," *IEEE Transactions on Wireless Communications*, vol. 7, no. 4, 2008.
- [46] "Ns-2 simulation tool," <http://www.isi.edu/nsnam/ns/>, February 2014.
- [47] F. Rossetto and M. Zorzi, "Enhancing spatial reuse in ad hoc networks by carrier sense adaptation," in *Proc. of the 26th IEEE/AFCEA Military Communications Conference, (MILCOM 2007)*. IEEE, 2007, pp. 1–6.
- [48] P. Gupta and P. Kumar, "The capacity of wireless networks," *IEEE Transactions on Information Theory*, vol. 46, no. 2, pp. 388–404, 2000.
- [49] G. Bianchi and I. Tinnirello, "Kalman filter estimation of the number of competing terminals in an IEEE 802.11 network," in *Proc. of the 22nd Annual Joint Conference of the IEEE Computer and Communications Societies (INFOCOM 2003)*, vol. 2. IEEE, 2003, pp. 844–852.
- [50] O. Acholem and B. Harvey, "Throughput performance in multi-hop networks using adaptive carrier sensing threshold," in *Proc. of the IEEE SoutheastCon 2010*. IEEE, 2010.
- [51] J. Zhu, X. Guo, S. Roy, and K. Papagiannaki, "CSMA self-adaptation based on interference differentiation," in *Proc. of the IEEE Global Telecommunications Conference (GLOBECOM 2007)*. IEEE, 2007, pp. 4946–4951.
- [52] H. Ma, R. Vijayakumar, S. Roy, and J. Zhu, "Optimizing 802.11 wireless mesh networks based on physical carrier sensing," *IEEE/ACM Transactions on Networking*, vol. 17, no. 5, pp. 1550–1563, 2009.
- [53] H. Ma, E. Alotaibi, and S. Roy, "Analysis and simulation model of physical carrier sensing in IEEE 802.11 mesh networks," in *OPNET-WORK Conference (OPNETWORK 2006)*, 2006.
- [54] H. Ma and S. Roy, "Simple and effective carrier sensing adaptation for multi rate ad-hoc mesh networks," in *Proc. of the IEEE International Conference on Mobile Ad hoc and Sensor Systems (MASS 2006)*. IEEE, 2006, pp. 795–800.
- [55] H. Ma, S. Shin, and S. Roy, "Optimizing throughput with carrier sensing adaptation for IEEE 802.11 mesh networks based on loss differentiation," in *Proc. of the IEEE International Conference on Communications (ICC 2007)*. IEEE, 2007, pp. 4967–4972.
- [56] J. Zhu, B. Metzler, X. Guo, and Y. Liu, "Adaptive CSMA for scalable network capacity in high-density WLAN: a hardware prototyping approach," in *Proc. of the 25th Annual Joint International Conference on IEEE Computer Communications and Societies (INFOCOM 2006)*, vol. 6, 2006.
- [57] B. Fonseca, "A distributed procedure for carrier sensing threshold adaptation in CSMA-based mobile ad hoc networks," in *Proc. of the 66th IEEE Vehicular Technology Conference (VTC 2006)*. IEEE, 2007, pp. 66–70.
- [58] J. Liu, L. Perrone, D. Nicol, M. Liljenstam, C. Elliott, and D. Pearson, "Simulation modeling of large-scale ad-hoc sensor networks," in *Proc. of the European Interoperability Workshop*, 2001.
- [59] K. Park, L. Kim, and J. Hou, "Adaptive physical carrier sense in topology-controlled wireless networks," *IEEE Transactions on Mobile Computing*, vol. 9, no. 1, pp. 87–97, 2010.
- [60] N. Li, J. Hou, and L. Sha, "Design and analysis of an MST-based topology control algorithm," in *Proc. of the 22nd Annual Joint Conference of the IEEE Computer and Communications Societies (INFOCOM 2003)*, vol. 3. IEEE, 2003, pp. 1702–1712.
- [61] "J-sim simulation tool," <http://www.j-sim.org>, February 2014.
- [62] L. Wang, K. Wu, and M. Hamdi, "Combating hidden and exposed terminal problems in wireless networks," 2012.
- [63] K. Tan, J. Fang, Y. Zhang, S. Chen, L. Shi, J. Zhang, and Y. Zhang, "Fine-grained channel access in wireless LAN," *ACM SIGCOMM Computer Communication Review*, vol. 40, no. 4, pp. 147–158, 2010.
- [64] "Ns-3 simulation tool," <http://nsnam.isi.edu/nsnam/index.php/User%2FInformation>, February 2014.
- [65] S. Katti, S. Gollakota, and D. Katabi, "Embracing wireless interference: analog network coding," in *ACM SIGCOMM Computer Communication Review*, vol. 37, no. 4. ACM, 2007, pp. 397–408.
- [66] K. Wu, H. Tan, H.-L. Ngan, Y. Liu, and L. M. Ni, "Chip error pattern analysis in IEEE 802.15.4," *Mobile Computing, IEEE Transactions on*, vol. 11, no. 4, pp. 543–552, 2012.
- [67] Y. Ko, V. Shankarkumar, and N. Vaidya, "Medium access control protocols using directional antennas in ad hoc networks," in *Proc. of the 19th Annual Joint Conference of the IEEE Computer and Communications Societies*, vol. 1. IEEE, 2000, pp. 13–21.
- [68] A. Nasipuri, S. Ye, J. You, and R. Hiroamoto, "A MAC protocol for mobile ad hoc networks using directional antennas," in *Proc. of the IEEE Wireless Communications and Networking Conference (WCNC 2000)*, vol. 3. IEEE, 2000, pp. 1214–1219.
- [69] S. Bandyopadhyay, K. Hasuiki, S. Horisawa, and S. Tawara, "An adaptive MAC protocol for wireless ad hoc community network (WACNet) using electronically steerable passive array radiator antenna," in *Proc. of the IEEE Global Telecommunications Conference (GLOBECOM 2001)*, vol. 5. IEEE, 2001, pp. 2896–2900.
- [70] J. Bordim, T. Ueda, and S. Tanaka, "Delivering the benefits of directional communications for ad hoc networks through an efficient directional MAC protocol," *Springer Journal on Telecommunications and Networking-ICT*, pp. 461–470, 2004.
- [71] Z. Huang, C. Shen, C. Srisathapornphat, and C. Jaikao, "A busy-tone based directional MAC protocol for ad hoc networks," in *Proc. of the 21st IEEE/AFCEA Military Communications Conference, (MILCOM 2007)*, vol. 2. IEEE, 2002, pp. 1233–1238.
- [72] R. R. Choudhury and N. H. Vaidya, "Deafness: A MAC problem in ad hoc networks when using directional antennas," in *Network Protocols, 2004. ICNP 2004. Proceedings of the 12th IEEE International Conference on*. IEEE, 2004, pp. 283–292.
- [73] J. Bordim, T. Hunziker, and K. Nakano, "Adaptive carrier sensing and packet sending—an alternative to boost the performance in directional communications," in *Proc. of the 6th International conference on Parallel and Distributed Computing, Applications and Technologies, (PDCAT 2005)*. IEEE, 2005, pp. 274–279.
- [74] C. Thorpe, S. Murphy, and L. Murphy, "IEEE 802.11k-enabled adaptive carrier sense management mechanism (KAPCS2)," in *Proc. of the 12th IFIP/IEEE International Symposium on Integrated Network Management (IM 2011)*. IFIP/IEEE, 2011.
- [75] IEEE Standard for Information Technology - Telecommunications and information exchange between systems - Local and metropolitan area networks - Local and metropolitan area networks Specific requirements Part 11: Wireless LAN Medium Access Control (MAC) and Physical Layer (PHY) Specifications, IEEE Standard 802.11k-2008 Std.
- [76] C. Thorpe, S. Murphy, and L. Murphy, "IEEE 802.11k enabled adaptive physical carrier sense mechanism for wireless networks (K-APCS)," in *Proc. of the 12th ACM International Conference on Modeling, Analysis and Simulation of Wireless and Mobile Systems (MSWIM 2009)*. ACM, 2009, pp. 209–215.
- [77] E. Haghani, M. N. Krishnan, and A. Zakhor, "Adaptive carrier-sensing for throughput improvement in IEEE 802.11 networks," in *Global Telecommunications Conference (GLOBECOM 2010)*, 2010 IEEE. IEEE, 2010, pp. 1–6.
- [78] M. N. Krishnan, S. Pollin, and A. Zakhor, "Local estimation of probabilities of direct and staggered collisions in 802.11 WLANs," in *Global Telecommunications Conference, 2009. GLOBECOM 2009. IEEE*. IEEE, 2009, pp. 1–8.
- [79] M. Christine, M. N. Krishnan, S. Ng, E. Haghani, and A. Zakhor, "Local estimation of collision probabilities in 802.11 WLANs: An experimental study," in *Wireless Communications and Networking Conference (WCNC), 2011 IEEE*. IEEE, 2011, pp. 43–48.
- [80] Z. Zeng, Y. Yang, and J. C. Hou, "How physical carrier sense affects system throughput in IEEE 802.11 wireless networks," in *INFOCOM*

2008. *The 27th Conference on Computer Communications*. IEEE, 2008, pp. 1445–1453.
- [81] F. P. Kelly, A. K. Maulloo, and D. K. Tan, “Rate control for communication networks: shadow prices, proportional fairness and stability,” *Journal of the Operational Research society*, vol. 49, no. 3, pp. 237–252, 1998.
- [82] G. Jakllari, S. Krishnamurthy, M. Faloutsos, P. Krishnamurthy, and O. Ercetin, “A framework for distributed spatio-temporal communications in mobile ad hoc networks,” in *Proc. of the IEEE International Conference on Computer Communications (INFOCOM 2006)*, 2006, pp. 1–13.
- [83] Y. Hua, Q. Zhang, and Z. Niu, “A cooperative mac protocol with virtual-antenna array support in a multi-ap wlan system,” *Wireless Communications, IEEE Transactions on*, vol. 8, no. 9, pp. 4806–4814, 2009.
- [84] —, “Distributed physical carrier sensing adaptation scheme in cooperative map wlan,” in *Global Telecommunications Conference, 2009. GLOBECOM 2009. IEEE*. IEEE, 2009, pp. 1–6.
- [85] J. Fuemmeler, N. H. Vaidya, and V. V. Veeravalli, “Selecting transmit powers and carrier sense thresholds for csma protocols,” *Technique report, University of Illinois at Urbana-Champaign*, 2004.
- [86] M. Takai, J. Martin, and R. Bagrodia, “Effects of wireless physical layer modeling in mobile ad hoc networks,” in *Proc. of the 2nd ACM International Symposium on Mobile Ad Hoc Networking & Computing (MobiHoc 2001)*. ACM, 2001, pp. 87–94.
- [87] D. Kotz, C. Newport, R. Gray, J. Liu, Y. Yuan, and C. Elliott, “Experimental evaluation of wireless simulation assumptions,” in *Proc. of the 7th ACM International Symposium on Modeling, Analysis and Simulation of Wireless and Mobile Systems (MSWIM 2004)*. ACM, 2004, pp. 78–82.
- [88] M. Torrent-Moreno, D. Jiang, and H. Hartenstein, “Broadcast reception rates and effects of priority access in 802.11-based vehicular ad-hoc networks,” in *Proceedings of the 1st ACM international workshop on Vehicular ad hoc networks*. ACM, 2004, pp. 10–18.
- [89] H. S. Chhaya and S. Gupta, “Performance modeling of asynchronous data transfer methods of ieee 802.11 mac protocol,” *Wireless networks*, vol. 3, no. 3, pp. 217–234, 1997.
- [90] H. Zhai, Y. Kwon, and Y. Fang, “Performance analysis of ieee 802.11 mac protocols in wireless lans,” *Wireless communications and mobile computing*, vol. 4, no. 8, pp. 917–931, 2004.
- [91] F. Cali, M. Conti, and E. Gregori, “Ieee 802.11 protocol: design and performance evaluation of an adaptive backoff mechanism,” *Selected Areas in Communications, IEEE Journal on*, vol. 18, no. 9, pp. 1774–1786, 2000.
- [92] X. Qiang and Z. Chongqing, “A framework for investigating the performances of wireless ad hoc networks,” in *Computer Science and Information Processing (CSIP), 2012 International Conference on*. IEEE, 2012, pp. 108–112.
- [93] H. Zhai, Y. Fang *et al.*, “Physical carrier sensing and spatial reuse in multirate and multihop wireless ad hoc networks,” in *Proc. IEEE Infocom*, vol. 6, 2006.
- [94] T.-S. Kim, H. Lim, and J. C. Hou, “Improving spatial reuse through tuning transmit power, carrier sense threshold, and data rate in multihop wireless networks,” in *Proceedings of the 12th annual international conference on Mobile computing and networking*. ACM, 2006, pp. 366–377.
- [95] T.-Y. Lin and J. C. Hou, “Interplay of spatial reuse and sinr-determined data rates in csma/ca-based, multi-hop, multi-rate wireless networks,” in *INFOCOM 2007. 26th IEEE International Conference on Computer Communications*. IEEE, 2007, pp. 803–811.
- [96] J. Heidemann, N. Bulusu, J. Elson, C. Intanagonwiwat, K. Lan, Y. Xu, W. Ye, D. Estrin, and R. Govindan, “Effects of detail in wireless network simulation,” *Proc. of the SCS Multiconference on Distributed Simulation*, pp. 3–11, 2001.
- [97] J. Liu, Y. Yuan, D. Nicol, R. Gray, C. Newport, D. Kotz, and L. Perrone, “Simulation validation using direct execution of wireless ad-hoc routing protocols,” in *Proc. of the 18th Workshop on IEEE Parallel and Distributed Simulation (PADS 2004)*. IEEE, 2004, pp. 7–16.
- [98] D. Cavin, Y. Sasson, and A. Schiper, “On the accuracy of MANET simulators,” in *Proc. of the 2nd ACM International Workshop on Principles of Mobile Computing (POMC 2002)*. ACM, 2002, pp. 38–43.
- [99] J. A. Fuemmeler, N. H. Vaidya, and V. V. Veeravalli, “Selecting transmit powers and carrier sense thresholds in csma protocols for wireless ad hoc networks,” in *Proceedings of the 2nd annual international workshop on Wireless internet*, ser. WICON ’06. New York, NY, USA: ACM, 2006. [Online]. Available: <http://doi.acm.org/10.1145/1234161.1234176>
- [100] P. M. van de Ven, A. J. Janssen, and J. S. van Leeuwen, “Optimal tradeoff between exposed and hidden nodes in large wireless networks,” *arXiv preprint arXiv:1004.1058*, 2010.
- [101] S. Roy, H. Ma, R. Vijaykumar, and J. Zhu, “Optimizing 802.11 wireless mesh networks performance using physical carrier sensing,” *UWETR 2006*, vol. 5, 2006.
- [102] L. Li, J. Y. Halpern, P. Bahl, Y.-M. Wang, and R. Wattenhofer, “Analysis of a cone-based distributed topology control algorithm for wireless multi-hop networks,” in *Proceedings of the twentieth annual ACM symposium on Principles of distributed computing*. ACM, 2001, pp. 264–273.
- [103] S. Narayanaswamy, V. Kawadia, R. S. Sreenivas, and P. Kumar, “Power control in ad-hoc networks: Theory, architecture, algorithm and implementation of the compow protocol,” in *European Wireless Conference*, vol. 2002, 2002.
- [104] R. Ramanathan and R. Rosales-Hain, “Topology control of multihop wireless networks using transmit power adjustment,” in *INFOCOM 2000. Nineteenth Annual Joint Conference of the IEEE Computer and Communications Societies. Proceedings. IEEE*, vol. 2. IEEE, 2000, pp. 404–413.
- [105] R. Wattenhofer, L. Li, P. Bahl, and Y.-M. Wang, “Distributed topology control for power efficient operation in multihop wireless ad hoc networks,” in *INFOCOM 2001. Twentieth Annual Joint Conference of the IEEE Computer and Communications Societies. Proceedings. IEEE*, vol. 3. IEEE, 2001, pp. 1388–1397.
- [106] J. P. Monks, V. Bharghavan, and W.-M. Hwu, “A power controlled multiple access protocol for wireless packet networks,” in *INFOCOM 2001. Twentieth Annual Joint Conference of the IEEE Computer and Communications Societies. Proceedings. IEEE*, vol. 1. IEEE, 2001, pp. 219–228.
- [107] A. Muqattash and M. Krunz, “Power controlled dual channel (pcdc) medium access protocol for wireless ad hoc networks,” in *INFOCOM 2003. Twenty-Second Annual Joint Conference of the IEEE Computer and Communications. IEEE Societies*, vol. 1. IEEE, 2003, pp. 470–480.
- [108] —, “A single-channel solution for transmission power control in wireless ad hoc networks,” in *International Symposium on Mobile Ad Hoc Networking & Computing: Proceedings of the 5th ACM international symposium on Mobile ad hoc networking and computing*, vol. 24, no. 26, 2004, pp. 210–221.
- [109] A. Akella, G. Judd, S. Seshan, and P. Steenkiste, “Self-management in chaotic wireless deployments,” *Wireless Networks*, vol. 13, no. 6, pp. 737–755, 2007.

**Christina Thorpe, B.Sc., Ph.D.** Christina Thorpe received a B.Sc. in Computer Science from University College Dublin in 2005, and Ph.D. in Computer Science from University College Dublin in 2011. She is currently a Technical Research Manager in the Performance Engineering Laboratory and an Assistant Lecturer in the Institute of Technology Blanchardstown. Dr. Thorpe has published multiple conference papers on adaptive mechanisms for content distribution over IEEE 802.11 wireless networks, IPTV service management, and testing the Cloud.

**Liam Murphy B.E., M.Sc., Ph.D.** Liam Murphy received a B.E. in Electrical Engineering from University College Dublin in 1985, & an M.Sc. and Ph.D. in Electrical Engineering and Computer Sciences from the University of California, Berkeley in 1988 and 1992 respectively. He is currently a Professor of Computer Science & Informatics at University College Dublin, where he is Director of the Performance Engineering Laboratory. Prof. Murphy has published almost 150 refereed journal and conference papers on various topics, including multimedia transmissions, dynamic and adaptive resource allocation algorithms in computer/communication networks, and software development. His current research projects involve computer network convergence and software performance engineering. Prof. Murphy is a Member of the IEEE (Communications, Broadcasting, and Computer societies) and a Fellow of the Irish Computer Society.