

ULRR

Forecasting energy time-series data using a fuzzy ARTMAP neural network

Item Type	Meetings and Proceedings
Authors	de Assis Pedrobon Ferreira, Willian;Grout, Ian;da Silva, Alexandre César Rodrigues
Citation	2020 International Conference on Power, Energy and Innovations (ICPEI);pp.1-4
Publisher	IEEE Computer Society
Download date	2026-03-11 06:34:20
Item License	https://creativecommons.org/licenses/by-nc-sa/1.0/
Link to Item	https://hdl.handle.net/10344/10455

Forecasting energy time-series data using a fuzzy ARTMAP neural network

Willian de Assis Pedrobon
Ferreira
Faculdade de Engenharia
Universidade Estadual Paulista
Ilha Solteira, Brazil
e-mail: willian.ferreira@unesp.br

Ian Grout
Department of Electronic and
Computer Engineering
University of Limerick
Limerick, Ireland
e-mail: Ian.Grout@ul.ie

Alexandre César Rodrigues da
Silva
Faculdade de Engenharia
Universidade Estadual Paulista
Ilha Solteira, Brazil
e-mail: alexandre.cr.silva@unesp.br

Abstract—Time-series forecasting is an important field of machine learning and is fundamental in analyzing trends based on historical data from various sources. In this paper, a fuzzy ARTMAP neural network for time-series forecasting is presented. To validate the proposed system, two energy-related datasets from Great Britain were selected. With a promising processing time and accuracy as good as a traditional machine learning algorithm, the fuzzy ARTMAP neural network has shown that can be a good option to perform forecasting considering different time-based data issues.

Keywords—time-series forecasting, fuzzy ARTMAP neural network, energy data

I. INTRODUCTION

Constant monitoring associated with technological advances has changed the way in which to analyze existing behaviors and patterns in modern society. With a dense presence of sensors that capture information from a wide variety of sources, large databases are being created. A common way to handle continuous sampling big data sources is through time-series, which are composed of sequential observations over a time interval and can comprise information from various fields such as economics, engineering, and natural sciences. Usually, these data have dependencies whose patterns can be analyzed [1]. Examining characteristics from various data sources with artificial intelligence (AI) algorithms allow computational interfaces to learn from existing patterns. Thus, intelligent and autonomous systems can be developed capable of predicting future events based on the experience obtained from observed past events.

Nowadays, there have been several studies undertaken which have been interested in energy data time-series. Many machine learning (ML) techniques are used to analyze trends in systems that deal with energy aspects, such as the use of regression algorithms [2] and artificial neural networks [3] in energy price forecasting. Additionally, deep learning (DL), an extension of machine learning, is also present in this scenario, as energy load prediction [4]. Another global concern related to energy issues is environmental preservation. Aligning the growing energy demand resulting from the rapid development of large urban centers with efficient and sustainable energy resources management has become a challenge [5]. A notable case is the incentive to reduce carbon dioxide (CO₂)

emissions in electricity generation, as adopted by the government of Great Britain (GB) [6]. Currently, the United Kingdom's major single carbon dioxide source is electricity generation, producing about a third of emissions [7]. Prediction systems have the potential to assist issues of energy expansion planning without damaging the environment.

Considering the presented context, aiming at the analysis and prediction of energy datasets, this paper proposes the development of a forecasting system using a fuzzy ARTMAP neural network. The modeling of time-series as a supervised training method allows for the evaluation of the proposed methodology with data corresponding to gas demand and carbon intensity estimation from the GB energy system. This paper is organized as follows. Section II introduces the fuzzy ARTMAP neural network. The application examples and results discussion are presented in Section III, and in Section IV, the conclusions are presented.

II. FUNDAMENTALS OF ADAPTIVE RESONANCE THEORY NEURAL NETWORKS

The adaptive resonance theory (ART) was proposed in 1976 by Stephen Grossberg as a model inspired by the cognitive capacity of biological systems based on two dilemmas: plasticity and stability. Plasticity represents the ability to learn new patterns as the neural network interacts with the external agents, grouping new input patterns into specific clusters. On the other hand, stability ensures the maintenance of previously acquired knowledge, separating the newly created patterns from those already existing [8].

The ART neural network was proposed in 1987 (*ART-1*), which processes only binary data applying unsupervised learning to group input patterns. In 1991 a new ART architecture emerged, called ARTMAP, which uses supervised training consisting of two ART modules (*ART_a* and *ART_b*) connected by the *Inter-ART* module as shown in Fig. 1. In 1992, some fuzzy logic operators were integrated into ARTMAP to create the fuzzy ARTMAP neural network [9]. This approach can process analog and binary data.

The submodules *ART_a* and *ART_b* are responsible, respectively, for learning and grouping the similarities of the input and output patterns presented to the neural network. Thus, during training, for each input pattern, a corresponding output value is presented. After the

ART processing has finished, the *Inter-ART* subsystem maps the ART_a and ART_b encoded information, which characterizes the supervised training, to the fuzzy ARTMAP architecture.

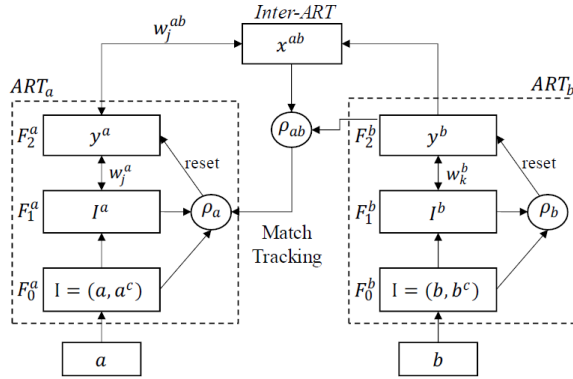

Fig. 1. Fuzzy ARTMAP diagram.

One feature that makes the fuzzy ARTMAP neural network, as well as the other ART architectures, stand out from other ML neural networks is the ability to perform incremental and online training without the need to apply offline optimization processes, that is after the training phase has been completed [9]. Thus, training occurs continuously without the need to be restarted as new patterns are presented to the neural network. With online training and optimized response time, ART neural networks are interesting models for performing time-series forecasting. Some ART applications considering energy aspects are electric load forecasting [10], energy management systems [11], and natural elements forecasting that can be applied in the analysis of renewable electricity generation, such as wind speed [12]. The subsection below presents the modeling of time-series to be processed by a fuzzy ARTMAP neural network.

A. Fuzzy ARTMAP methodology to process time-series data

To analyze time-series data with a fuzzy ARTMAP neural network, it is necessary to obtain a supervised training model from an interval time discretized data. The methodology employed in this paper was to construct input pattern vectors a for submodule ART_a , as depicted in Fig. 1, with two components. The first was the *time* component (e.g., day, month, and year), that identifies the timestamp t of each time-series value $v(t)$. The second component was n values $v(t)$ before a timestamp t . The desired neural network output, the b vector presented to ART_b submodule, was the $v(t+1)$ value, which represented the subsequent instant of the time-series. Therefore, fuzzy ARTMAP's input patterns as shown in (1) and (2):

$$a = [time, v(t-n), \dots, v(t-1), v(t)] \quad (1)$$

$$b = [v(t+1)] \quad (2)$$

The values $v(t-n)$ represent feedback output loops [10], resulting in a neural network with recurrent behavior.

Fig. 2 shows the processing steps of the implemented Python software. The raw data from a time-series dataset is loaded into the software using the Pandas DataFrame data structure. In the preprocessing phase, the neural network input patterns are formatted. During the fuzzy ARTMAP training, some learning aspects are defined by its parameters. In the prediction phase, only the ART_a module receives information, and the neural network output is obtained through the *Inter-ART* w_j^{ab} weight matrix that maps the correspondence between ART_a and ART_b categories. All fuzzy ARTMAP arithmetic operations were implemented using the NumPy Python library.

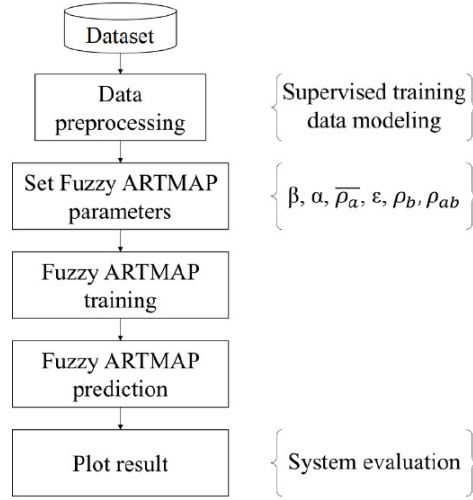

Fig. 2. Processing steps of the proposed system.

Forecasting evaluations were carried out by considering the mean absolute percentage error (MAPE) as shown in (3):

$$MAPE = \frac{100}{n} \sum_{i=1}^n \left| \frac{v(t) - p(t)}{v(t)} \right| \quad (3)$$

where n is the number of forecasted values, $v(t)$ is the real time-series value at instant t , and $p(t)$ is the fuzzy ARTMAP output.

III. SYSTEM APPLICATION AND DISCUSSION

Converting time-series data to a supervised training model, fuzzy ARTMAP can be efficient to forecast several quantities. Considering energy data, two datasets were selected to analyze the performance of the proposed methodology.

A. Gas demand and supply source forecasting

An important application of forecasting energy services is the study of energy source demand. For example, being able to project the future behavior of the analyzed resource allows for the creation of strategies to solve, or at least decrease, losses caused by unexpected situations.

This study considered the GB gas demand [13] using selected UK Continental Shelf (UKCS) data, which is one of the sources that feed the GB National Transmission System gas demand. Fuzzy ARTMAP training data are plotted in Fig. 3, consisting of the monthly total UKCS gas supplies from June 2012 to June 2018. The forecasting considered one year ahead after the last training month.

In this paper, a fuzzy ARTMAP neural network was proposed to forecasting time-series data. Focusing on energy data applications, it was verified that the performance of the implemented software system is satisfactory concerning the accuracy and processing time, as it could be verified by comparing the fuzzy ARTMAP forecasting results with the real data from the considered time-series. It was also possible to compare the behavior of the fuzzy ARTMAP with a regression algorithm, making it more evident that ART neural networks can improve the development of machine learning energy forecasting systems.

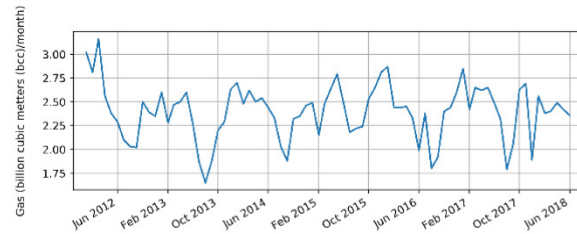

Fig. 3. Gas demand training data.

Applying the proposed modeling to obtain the input fuzzy ARTMAP patterns, the *time* input component was composed by month and year, and 2 previous gas demand values were considered, obtaining 75 input patterns to perform the neural network training. The fuzzy ARTMAP parameters are shown in TABLE I.

TABLE I. GAS DEMAND FUZZY ARTMAP PARAMETERS

Parameter	Value
Number of input patterns	75
Training rate (β)	1.0
Choice parameter (α)	2.0
ART_a baseline vigilance parameter (ρ_a)	0.97
ART_a vigilance parameter increment (ϵ)	0.0001
ART_b vigilance parameter (ρ_b)	0.97
<i>Inter-ART</i> vigilance parameter (ρ_{ab})	1.0

In this paper, the experiments were executed on a laptop computer with an Intel Core i5-8250U CPU and 8 GB of RAM. The results are shown in TABLE II, and Fig. 4 shows the real and forecasted gas demand values.

TABLE II. GAS DEMAND FORECASTING RESULTS

Item	Value
Number of clusters ART_a	84
Number of clusters ART_b	14
MAPE (%)	4.95
Processing time (s)	0.22

Fuzzy ARTMAP training considering gas demand monthly average over the 6-year period generated one

year ahead forecast with MAPE of 4.95%. The 0.22 s processing time represents the entire fuzzy ARTMAP run, that is, both training and prediction phases.

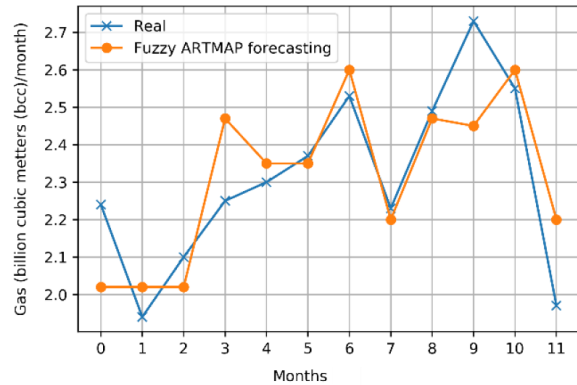

Fig. 4. One year ahead gas demand forecasting.

B. Carbon intensity forecasting

Another example of energy data time-series is carbon intensity. This estimation represents the amount of CO₂ produced per kilowatt-hour of electricity consumed considering corresponding values to each fuel type. Besides, correction factors are applied regarding transmission and distribution losses [14]. To perform one day ahead forecasting with fuzzy ARTMAP, this case considered the GB energy dataset from March 10th to March 24th, 2020 [15], which are plotted in Fig. 5.

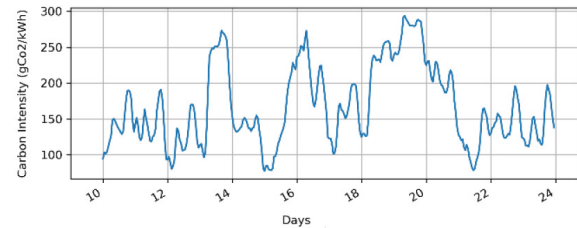

Fig. 5. Carbon intensity training data.

Each neural network input pattern considered 12 previous values of the time-series, and the *time* component contained the day of the month and the hour of the day. The parameters of fuzzy ARTMAP used in this evaluation are listed in TABLE III.

TABLE III. CARBON INTENSITY FUZZY ARTMAP PARAMETERS

Parameter	Value
Number of input patterns	336
Training rate (β)	1.0
Choice parameter (α)	0.7
ART_a baseline vigilance parameter (ρ_a)	0.95
ART_a vigilance parameter increment (ϵ)	0.0001
ART_b vigilance parameter (ρ_b)	0.98
<i>Inter-ART</i> vigilance parameter (ρ_{ab})	1.0

TABLE IV shows the fuzzy ARTMAP forecasting results corresponding to March 24th, 2020. The greater number of training examples compared to gas demand study generated more clusters during the fuzzy ARTMAP training and additionally increased the

processing time. As the size of the datasets increases, processing time can become a bottleneck depending on the application. This question could be optimized considering fuzzy ARTMAP neural networks implemented in compiled software, such as C, instead of Python which is an interpreted programming language.

TABLE IV. CARBON INTENSITY FORECASTING RESULTS

Item	Value
Number of clusters ART_a	301
Number of clusters ART_b	43
MAPE (%)	9.5
Processing time (s)	2.79

The National Grid API [15] provides carbon intensity forecasting via a rolling-window linear regression machine learning algorithm considering only the time-series electricity generation data [14]. The National Grid API forecasts as well as the fuzzy ARTMAP estimation and the real carbon intensity values are presented in the graph of Fig. 6.

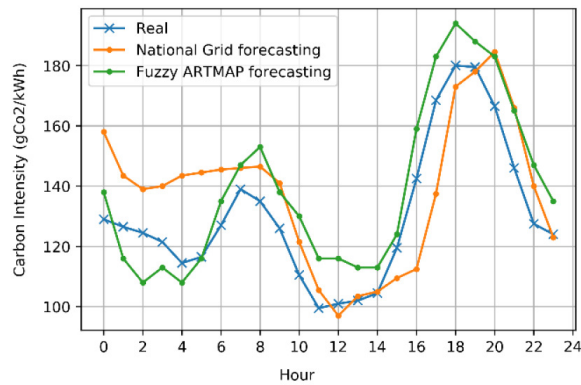

Fig. 6. One day ahead carbon intensity forecasting comparison.

The forecasting MAPE of National Grid API and fuzzy ARTMAP were respectively 10.9% and 9.5%. Therefore, the fuzzy ARTMAP accuracy can achieve the performance of traditional time-series forecasting algorithms, such as rolling-window regressions. The fundamental characteristics of the ART neural networks family, that is, plasticity and stability, guaranteed rapid convergence and satisfactory effectiveness in situations with different temporal issues. Another capability of ART neural networks that stands out is that of incremental and online learning, which is essential for forecasting time-series data as there is no need to restart training when new input patterns appear.

IV. CONCLUSIONS

In this paper, a fuzzy ARTMAP neural network was proposed for forecasting time-series data. Focusing on energy data applications, it was verified that the performance of the implemented software system is satisfactory concerning the accuracy and

processing time by comparing the fuzzy ARTMAP forecasting results with the real data from the considered time-series. It was also possible to compare the behavior of the fuzzy ARTMAP with a regression algorithm, making it more evident that ART neural networks can improve the development of machine learning energy forecasting systems.

ACKNOWLEDGMENT

This study was financed in part by the Coordenação de Aperfeiçoamento de Pessoal de Nível Superior - Brasil (CAPES) - Finance Code 001.

REFERENCES

- [1] G. E. P. Box, G. M. Jenkins, G. C. Reinsel, G and M Ljung, Time series analysis: forecasting and control, 5th ed, John Wiley & Sons, 2015.
- [2] G. Dudek, "Probabilistic forecasting of electricity prices using kernel regression", 2018 15th International Conference on the European Energy Market (EEM), Lodz, 2018, pp. 1-5.
- [3] C. Wang, J. Xu, K. Xu, K. Yuan, Y. Qi and Y. Mu, "Rolling forecast nature gas spot price with back propagation neural network", 2019 IEEE Sustainable Power and Energy Conference (ISPEC), Beijing, China, 2019, pp. 2473-2477.
- [4] C. Heghedus, A. Chakravorty and C. Rong, "Energy load forecasting using deep learning", 2018 IEEE International Conference on Energy Internet (ICEI), Beijing, 2018, pp. 146-151.
- [5] A. N. Matheri, J. C. Ngila, C. K. Njenga, M. Belaid and N. J. van Rensburg, "Smart city energy trend transformation in the fourth industrial revolution digital disruption", 2019 IEEE International Conference on Industrial Engineering and Engineering Management (IEEM), Macao, 2019, pp. 978-984.
- [6] I. Staffell, "Measuring the progress and impacts of decarbonisation British electricity", Energy Policy, 2017, pp. 463-475.
- [7] Edinburgh Energy & Environment Consultancy, *About supplier fuel mix*. Accessed on: April 22, 2020. [Online]. Available: <http://electricityinfo.org/about-supplier-fuel-mix/>
- [8] G. A. Carpenter and S. A. Grossberg, "A massively parallel architecture for a self-organizing neural pattern recognition machine", Computer Vision, Graphics, and Image Processing, 1987, pp. 54-115.
- [9] G. A. Carpenter, S. Grossberg, N. Markuzon, J. H. Reynolds and D. B. Rosen, "Fuzzy ARTMAP: A neural network architecture for incremental supervised learning of analog multidimensional maps", IEEE Transactions on Neural Networks, vol. 3, no. 5, pp. 698-713, Sept. 1992.
- [10] M. L. M. Lopes, C. R. Minussi and A. D. P. Lotufo, "Electric load forecasting using a fuzzy ART&ARTMAP neural network", Applied Soft Computing, 2004, pp. 235-244.
- [11] M. Mokhtar and J. Howe, "Comparing the online learning capabilities of gaussian ARTMAP and fuzzy ARTMAP for building energy management systems", Expert Systems with Applications, 2013, pp. 6007-6018.
- [12] A. Ul. Haque and J. Meng, "Short-term wind speed forecasting based on fuzzy ARTMAP", International Journal of Green Energy, 2011, pp. 65-80.
- [13] OFGEM, *Gas demand and supply source by month (GB)*. Accessed on: April 13, 2020. [Online]. Available: <https://www.ofgem.gov.uk/data-portal/gas-demand-and-supply-source-month-gb>
- [14] National Grid, Carbon Intensity Forecast Methodology, 2017.
- [15] National Grid ESO, *Carbon Intensity API*. Accessed on: April 13, 2020. [Online]. Available: <https://carbonintensity.org.uk/>